

Carrier-Current Techniques

wired-wireless broadcasting

By Ernest G. Wilson

All rights reserved. No part of this book may be reproduced in any form without written permission from the publisher.

Made in the United States of America

by TASCARD Productions P.O. Box 130, Pomona, CA 92367

CONTENTS

Introduction	1
The Wire-Wireless System	2
Carrier-Current and the Law	3
How to Select Your Frequency	4
Locating an Existing Frequency	5
Wired-Wireless Systems	6
Carrier-Current Characteristics	7
(a) Power Output	8
(b) Frequency	9
(c) Bandwidth	10
(d) Modulation	11
(e) Propagation	12
(f) Interference	13
(g) Safety	14
(h) Regulations	15
(i) Applications	16
(j) Advantages	17
(k) Disadvantages	18
(l) Future	19
(m) Summary	20
(n) References	21
(o) Bibliography	22
(p) Glossary	23
(q) Index	24
(r) Appendix	25
(s) Acknowledgments	26
(t) Author's Note	27
(u) Copyright	28
(v) Trademark	29
(w) Patent	30
(x) Disclaimer	31
(y) Liability	32
(z) Release	33
(aa) Waiver	34
(ab) Assumption of Risk	35
(ac) Indemnification	36
(ad) Arbitration	37
(ae) Mediation	38
(af) Dispute Resolution	39
(ag) Alternative Dispute Resolution	40
(ah) Conflict of Interest	41
(ai) Confidentiality	42
(aj) Non-Compete	43
(ak) Non-Solicit	44
(al) Non-Disparagement	45
(am) Assignment	46
(an) Subcontracting	47
(ao) Force Majeure	48
(ap) Entire Agreement	49
(aq) Severability	50
(ar) Construction	51
(as) Interpretation	52
(at) Notices	53
(au) Counterparts	54
(av) Electronic Signatures	55
(aw) Digital Signatures	56
(ax) Electronic Records	57
(ay) E-Records	58
(az) E-Transactions	59
(ba) E-Commerce	60
(bb) E-Government	61
(bc) E-Business	62
(bd) E-Marketing	63
(be) E-Advertising	64
(bf) E-Promotions	65
(bg) E-Recruitment	66
(bh) E-Procurement	67
(bi) E-Supply Chain	68
(bj) E-Logistics	69
(bk) E-Transportation	70
(bl) E-Healthcare	71
(bm) E-Education	72
(bn) E-Entertainment	73
(bo) E-Real Estate	74
(bp) E-Finance	75
(bq) E-Insurance	76
(br) E-Legal	77
(bs) E-Media	78
(bt) E-Telecommunications	79
(bu) E-Utilities	80
(bv) E-Transportation	81
(bw) E-Travel	82
(bx) E-Tourism	83
(by) E-Construction	84
(bz) E-Defense	85
(ca) E-Energy	86
(cb) E-Environment	87
(cc) E-International Trade	88
(cd) E-Globalization	89
(ce) E-Information Technology	90
(cf) E-Internet	91
(cg) E-Web	92
(ch) E-Search Engines	93
(ci) E-Advertising	94
(cj) E-Marketing	95
(ck) E-Promotions	96
(cl) E-Recruitment	97
(cm) E-Procurement	98
(cn) E-Supply Chain	99
(co) E-Logistics	100
(cp) E-Transportation	101
(cq) E-Healthcare	102
(cr) E-Education	103
(cs) E-Entertainment	104
(ct) E-Real Estate	105
(cu) E-Finance	106
(cv) E-Insurance	107
(cw) E-Legal	108
(cx) E-Media	109
(cy) E-Telecommunications	110
(cz) E-Utilities	111
(ca) E-Transportation	112
(cb) E-Travel	113
(cc) E-Tourism	114
(cd) E-Construction	115
(ce) E-Defense	116
(cf) E-Energy	117
(cf) E-Environment	118
(cf) E-International Trade	119
(cf) E-Globalization	120
(cf) E-Information Technology	121
(cf) E-Internet	122
(cf) E-Web	123
(cf) E-Search Engines	124
(cf) E-Advertising	125
(cf) E-Marketing	126
(cf) E-Promotions	127
(cf) E-Recruitment	128
(cf) E-Procurement	129
(cf) E-Supply Chain	130
(cf) E-Logistics	131
(cf) E-Transportation	132
(cf) E-Healthcare	133
(cf) E-Education	134
(cf) E-Entertainment	135
(cf) E-Real Estate	136
(cf) E-Finance	137
(cf) E-Insurance	138
(cf) E-Legal	139
(cf) E-Media	140
(cf) E-Telecommunications	141
(cf) E-Utilities	142
(cf) E-Transportation	143
(cf) E-Travel	144
(cf) E-Tourism	145
(cf) E-Construction	146
(cf) E-Defense	147
(cf) E-Energy	148
(cf) E-Environment	149
(cf) E-International Trade	150
(cf) E-Globalization	151
(cf) E-Information Technology	152
(cf) E-Internet	153
(cf) E-Web	154
(cf) E-Search Engines	155
(cf) E-Advertising	156
(cf) E-Marketing	157
(cf) E-Promotions	158
(cf) E-Recruitment	159
(cf) E-Procurement	160
(cf) E-Supply Chain	161
(cf) E-Logistics	162
(cf) E-Transportation	163
(cf) E-Healthcare	164
(cf) E-Education	165
(cf) E-Entertainment	166
(cf) E-Real Estate	167
(cf) E-Finance	168
(cf) E-Insurance	169
(cf) E-Legal	170
(cf) E-Media	171
(cf) E-Telecommunications	172
(cf) E-Utilities	173
(cf) E-Transportation	174
(cf) E-Travel	175
(cf) E-Tourism	176
(cf) E-Construction	177
(cf) E-Defense	178
(cf) E-Energy	179
(cf) E-Environment	180
(cf) E-International Trade	181
(cf) E-Globalization	182
(cf) E-Information Technology	183
(cf) E-Internet	184
(cf) E-Web	185
(cf) E-Search Engines	186
(cf) E-Advertising	187
(cf) E-Marketing	188
(cf) E-Promotions	189
(cf) E-Recruitment	190
(cf) E-Procurement	191
(cf) E-Supply Chain	192
(cf) E-Logistics	193
(cf) E-Transportation	194
(cf) E-Healthcare	195
(cf) E-Education	196
(cf) E-Entertainment	197
(cf) E-Real Estate	198
(cf) E-Finance	199
(cf) E-Insurance	200
(cf) E-Legal	201
(cf) E-Media	202
(cf) E-Telecommunications	203
(cf) E-Utilities	204
(cf) E-Transportation	205
(cf) E-Travel	206
(cf) E-Tourism	207
(cf) E-Construction	208
(cf) E-Defense	209
(cf) E-Energy	210
(cf) E-Environment	211
(cf) E-International Trade	212
(cf) E-Globalization	213
(cf) E-Information Technology	214
(cf) E-Internet	215
(cf) E-Web	216
(cf) E-Search Engines	217
(cf) E-Advertising	218
(cf) E-Marketing	219
(cf) E-Promotions	220
(cf) E-Recruitment	221
(cf) E-Procurement	222
(cf) E-Supply Chain	223
(cf) E-Logistics	224
(cf) E-Transportation	225
(cf) E-Healthcare	226
(cf) E-Education	227
(cf) E-Entertainment	228
(cf) E-Real Estate	229
(cf) E-Finance	230
(cf) E-Insurance	231
(cf) E-Legal	232
(cf) E-Media	233
(cf) E-Telecommunications	234
(cf) E-Utilities	235
(cf) E-Transportation	236
(cf) E-Travel	237
(cf) E-Tourism	238
(cf) E-Construction	239
(cf) E-Defense	240
(cf) E-Energy	241
(cf) E-Environment	242
(cf) E-International Trade	243
(cf) E-Globalization	244
(cf) E-Information Technology	245
(cf) E-Internet	246
(cf) E-Web	247
(cf) E-Search Engines	248
(cf) E-Advertising	249
(cf) E-Marketing	250
(cf) E-Promotions	251
(cf) E-Recruitment	252
(cf) E-Procurement	253
(cf) E-Supply Chain	254
(cf) E-Logistics	255
(cf) E-Transportation	256
(cf) E-Healthcare	257
(cf) E-Education	258
(cf) E-Entertainment	259
(cf) E-Real Estate	260
(cf) E-Finance	261
(cf) E-Insurance	262
(cf) E-Legal	263
(cf) E-Media	264
(cf) E-Telecommunications	265
(cf) E-Utilities	266
(cf) E-Transportation	267
(cf) E-Travel	268
(cf) E-Tourism	269
(cf) E-Construction	270
(cf) E-Defense	271
(cf) E-Energy	272
(cf) E-Environment	273
(cf) E-International Trade	274
(cf) E-Globalization	275
(cf) E-Information Technology	276
(cf) E-Internet	277
(cf) E-Web	278
(cf) E-Search Engines	279
(cf) E-Advertising	280
(cf) E-Marketing	281
(cf) E-Promotions	282
(cf) E-Recruitment	283
(cf) E-Procurement	284
(cf) E-Supply Chain	285
(cf) E-Logistics	286
(cf) E-Transportation	287
(cf) E-Healthcare	288
(cf) E-Education	289
(cf) E-Entertainment	290
(cf) E-Real Estate	291
(cf) E-Finance	292
(cf) E-Insurance	293
(cf) E-Legal	294
(cf) E-Media	295
(cf) E-Telecommunications	296
(cf) E-Utilities	297
(cf) E-Transportation	298
(cf) E-Travel	299
(cf) E-Tourism	300
(cf) E-Construction	301
(cf) E-Defense	302
(cf) E-Energy	303
(cf) E-Environment	304
(cf) E-International Trade	305
(cf) E-Globalization	306
(cf) E-Information Technology	307
(cf) E-Internet	308
(cf) E-Web	309
(cf) E-Search Engines	310
(cf) E-Advertising	311
(cf) E-Marketing	312
(cf) E-Promotions	313
(cf) E-Recruitment	314
(cf) E-Procurement	315
(cf) E-Supply Chain	316
(cf) E-Logistics	317
(cf) E-Transportation	318
(cf) E-Healthcare	319
(cf) E-Education	320
(cf) E-Entertainment	321
(cf) E-Real Estate	322
(cf) E-Finance	323
(cf) E-Insurance	324
(cf) E-Legal	325
(cf) E-Media	326
(cf) E-Telecommunications	327
(cf) E-Utilities	328
(cf) E-Transportation	329
(cf) E-Travel	330
(cf) E-Tourism	331
(cf) E-Construction	332
(cf) E-Defense	333
(cf) E-Energy	334
(cf) E-Environment	335
(cf) E-International Trade	336
(cf) E-Globalization	337
(cf) E-Information Technology	338
(cf) E-Internet	339
(cf) E-Web	340
(cf) E-Search Engines	341
(cf) E-Advertising	342
(cf) E-Marketing	343
(cf) E-Promotions	344
(cf) E-Recruitment	345
(cf) E-Procurement	346
(cf) E-Supply Chain	347
(cf) E-Logistics	348
(cf) E-Transportation	349
(cf) E-Healthcare	350
(cf) E-Education	351
(cf) E-Entertainment	352
(cf) E-Real Estate	353
(cf) E-Finance	354
(cf) E-Insurance	355
(cf) E-Legal	356
(cf) E-Media	357
(cf) E-Telecommunications	358
(cf) E-Utilities	359
(cf) E-Transportation	360
(cf) E-Travel	361
(cf) E-Tourism	362
(cf) E-Construction	363
(cf) E-Defense	364
(cf) E-Energy	365
(cf) E-Environment	366
(cf) E-International Trade	367
(cf) E-Globalization	368
(cf) E-Information Technology	369
(cf) E-Internet	370
(cf) E-Web	371
(cf) E-Search Engines	372
(cf) E-Advertising	373
(cf) E-Marketing	374
(cf) E-Promotions	375
(cf) E-Recruitment	376
(cf) E-Procurement	377
(cf) E-Supply Chain	378
(cf) E-Logistics	379
(cf) E-Transportation	380
(cf) E-Healthcare	381
(cf) E-Education	382
(cf) E-Entertainment	383
(cf) E-Real Estate	384
(cf) E-Finance	385
(cf) E-Insurance	386
(cf) E-Legal	387
(cf) E-Media	388
(cf) E-Telecommunications	389
(cf) E-Utilities	390
(cf) E-Transportation	391
(cf) E-Travel	392
(cf) E-Tourism	393
(cf) E-Construction	394
(cf) E-Defense	395
(cf) E-Energy	396
(cf) E-Environment	397
(cf) E-International Trade	398
(cf) E-Globalization	399
(cf) E-Information Technology	400
(cf) E-Internet	401
(cf) E-Web	402
(cf) E-Search Engines	403
(cf) E-Advertising	404
(cf) E-Marketing	405
(cf) E-Promotions	406
(cf) E-Recruitment	407
(cf) E-Procurement	408
(cf) E-Supply Chain	409
(cf) E-Logistics	410
(cf) E-Transportation	411
(cf) E-Healthcare	412
(cf) E-Education	413
(cf) E-Entertainment	414
(cf) E-Real Estate	415
(cf) E-Finance	416
(cf) E-Insurance	417
(cf) E-Legal	418
(cf) E-Media	419
(cf) E-Telecommunications	420
(cf) E-Utilities	421
(cf) E-Transportation	422
(cf) E-Travel	423
(cf) E-Tourism	424
(cf) E-Construction	425
(cf) E-Defense	426
(cf) E-Energy	427
(cf) E-Environment	428
(cf) E-International Trade	429
(cf) E-Globalization	430
(cf) E-Information Technology	431
(cf) E-Internet	432
(cf) E-Web	433
(cf) E-Search Engines	434
(cf) E-Advertising	435
(cf) E-Marketing	436
(cf) E-Promotions	437
(cf) E-Recruitment	438
(cf) E-Procurement	439
(cf) E-Supply Chain	440
(cf) E-Logistics	441
(cf) E-Transportation	442
(cf) E-Healthcare	443
(cf) E-Education	444
(cf) E-Entertainment	445
(cf) E-Real Estate	446
(cf) E-Finance	447
(cf) E-Insurance	448
(cf) E-Legal	449
(cf) E-Media	450
(cf) E-Telecommunications	451
(cf) E-Utilities	452
(cf) E-Transportation	453
(cf) E-Travel	454
(cf) E-Tourism	455
(cf) E-Construction	456
(cf) E-Defense	457
(cf) E-Energy	458
(cf) E-Environment	459
(cf) E-International Trade	460
(cf) E-Globalization	461
(cf) E-Information Technology	462
(cf) E-Internet	463
(cf) E-Web	464
(cf) E-Search Engines	465
(cf) E-Advertising	466
(cf) E-Marketing	467
(cf) E-Promotions	468
(cf) E-Recruitment	469
(cf) E-Procurement	470
(cf) E-Supply Chain	471
(cf) E-Logistics	472
(cf) E-Transportation	473
(cf) E-Healthcare	474
(cf) E-Education	475
(cf) E-Entertainment	476
(cf) E-Real Estate	477
(cf) E-Finance	478
(cf) E-Insurance	479
(cf) E-Legal	480
(cf) E-Media	481
(cf) E-Telecommunications	482
(cf) E-Utilities	483
(cf) E-Transportation	484
(cf) E-Travel	485
(cf) E-Tourism	486
(cf) E-Construction	487
(cf) E-Defense	488
(cf) E-Energy	489
(cf) E-Environment	490
(cf) E-International Trade	491
(cf) E-Globalization	492
(cf) E-Information Technology	493
(cf) E-Internet	494
(cf) E-Web	495
(cf) E-Search Engines	496
(cf) E-Advertising	497
(cf) E-Marketing	498
(cf) E-Promotions	499
(cf) E-Recruitment	500
(cf) E-Procurement	501
(cf) E-Supply Chain	502
(cf) E-Logistics	503
(cf) E-Transportation	504
(cf) E-Healthcare	505
(cf) E-Education	506
(cf) E-Entertainment	507
(cf) E-Real Estate	508

CONTENTS

Introduction	1
The Wired-Wireless System	2
Carrier-Current and the Law	4
How to Select Your Frequency	7
Locating an Operating Frequency	10
RF Distribution Systems	13
Carrier-Current Distribution	14
System Layout	15
Direct Radiation	19
Transmission by Induction	20
Transmission Lines	22
Transmission Line Installation	24
Transmitters and Repeaters	26
Fig. 10 - 100 milliwatt transmitter	30
Fig. 11A - 100 milliwatt repeater	32
Fig. 11D - 5 watt transmitter/repeater	38
RF Coupling and Power Splitting	40
Off-Air Monitoring	49
Commercial Equipment	50
Telephone Facilities	52
Studio Facilities	57
Appendices:	
(A) Common Coaxial Cable Characteristics	58
(B) Balanced Transmission Line Characteristics	59
(C) Sources	60
(D) References	61
(E) Fixed 600 Ohm Pads	62
(F) Fixed 50 and 75 Ohm Pads	63
(G) Typical RF Waveforms	64

INTRODUCTION

I've been playing around with radio and electronics since the late 1930's and both have kept me in a constant state of learning. My first Carrier-Current transmission was made in 1946. It covered a distance of about a half mile. The transmitter was made with 80 turns of #18 wire on a Quaker Oats cereal box, and a 6L6G tube. Today, of course, transmitters are constructed from ferrite core transformers and transistors, but the basic principles remain the same.

The basic reference then was the 1945 edition of "The Radio Amateur's Handbook", published by the Amateur Radio Relay League (ARRL). I still have that edition in my library - a prized possession.

Over the years I have been active in amateur radio, broadcasting, electronics, and education. Many times I have been asked about how to start a radio station and especially a low power AM or Carrier-Current station. The only written information I could direct them to was my copy of that 1945 ARRL Handbook.

A search for other information on the subject turned up only a few short publications. These were well written by college students, and by a Carrier-Current manufacturer, but most interested people have not been aware of them.

This book was written to fill the apparent gap between Carrier-Current (low power AM) techniques and the people that want that information. It is hoped we can bring you closer to your goals in broadcasting, and particularly in Carrier-Current broadcasting.

Good luck,

Ernest G. Wilson

THE WIRED - WIRELESS SYSTEM

The term "Carrier-Current" originated in the 1920's when the telephone industry developed methods for transmitting several conversations over a single pair of wires at the same time. The telephone industry used special lines specifically designed for the purpose.

Electric power companies soon discovered that they could use the same techniques utilizing their existing high-tension power lines. This enabled power companies to communicate between central offices and sub-station switching facilities with their own private telephone systems. The technique was further developed to provide remote control of unattended sub-stations. A "carrier" frequency far below that of the Standard Broadcast Band (AM) frequencies was used to avoid interference. The lower carrier frequency also permitted greater range of communications.

By the late 1930's the telephone industry developed other means of transmitting simultaneous messages over long distances. The use of Carrier-Current was dropped from use as far as telephone companies were concerned.

Also in the late 1930's radio hobbyists became interested and began experimenting with two-way stations. Carrier frequencies were kept between 150 kilohertz and 200 kilohertz to avoid interference with power company communications and the Standard Broadcast Band. Interest became quite intense in the early 1940's because Carrier-Current communications was the only form of radio allowed to hobbyists during the World War II years.

With Carrier-Current techniques fairly well established it was only natural that radio hobbyists would want to simulate commercial broadcast stations. During the late 1940's several Eastern colleges began broadcasting to the campus and to the dormitories. The idea quickly fired the imagination of radio enthusiasts at other schools and colleges, and even small towns and church groups. Here was an ideal "closed circuit" system that could bring news and other information to a small group of people. In rural areas a simple 25 watt transmitter, coupled to the community power lines, provided a range of up to 5 miles. City ranges however were limited to about 1 or 2 miles because of the greater "loading" of the power lines by lighting, appliances, motorized machinery, etc. The carrier frequency used was selected from the Standard Broadcast Band so that reception was possible with any standard AM radio.

Recent efforts include Carrier-Current paging and broadcasting services at military bases, hospitals, commercial buildings, urban ghetto areas, shopping centers, parking lots, drive-in churches, and hard-of-hearing assistance within a church.

The many advantages of Carrier-Current and limited area broadcasting continues to stimulate the imagination of broadcasters and potential broadcasters. Schools find a radio facility can be both avocational and vocational at the same time. Students develop vocational skills while having fun. Teachers are delighted to find students so eager to learn!

Neighborhood "bootleg" or "pirate" stations are becoming more popular as potential DJ's practice their future profession. Some younger DJ's that actually work at a commercial radio station during the day, practice with their own "home" station at night! One pirate station in Southern California had a coverage area of a couple hundred miles with illegal power and a good antenna system. The FCC shut it down. The audience was there however and the former pirate station owner went into a legitimate endeavor. He started a cable FM station and is reported as doing very well.

Some of the reasons a Carrier-Current or limited area broadcast station are so appealing are:

No FCC license is required by the station or its operators. Construction costs are small, much of the equipment can be home-made. The audience is clearly defined with predictable program tastes. Ideal system for schools, churches, shopping centers, drive-in theaters and small communities.

Of course there are some disadvantages also. These include:

Limited range when operating in accordance with FCC Rules

Power line electrical interference can affect reception quality

Other advantages and disadvantages will become apparent as you read through the following chapters.

For further information of possible uses of limited area broadcasting you can write to LPB, Inc. in Frazer, Pennsylvania. They have lists of schools, churches, and other facilities, that use Carrier-Current or limited area broadcasting in one way or another.

CARRIER-CURRENT AND THE LAW

Since Carrier-Current broadcasting is basically an AM radio service, it must share the radio spectrum. The Federal Communications Commission in the United States and the Canadian Department of Transport in Canada regulate the use of radio frequencies within their borders. Other countries have similar agencies. In hopes of minimizing harmful interference, they have established definite limits to the strength of radio waves emitted by non-licensed stations.

For the United States, these limits appear in Part 15 of the FCC's Rules. Part 15 allows two basic methods of radio wave transmission in the band of frequencies assigned to the Standard Broadcast service. These frequencies are between 535 kilohertz and 1605 kilohertz. Operation of any nonlicensed broadcast station on the FM broadcast band of 88 megahertz to 108 megahertz is prohibited.

The two basic methods of low power broadcasting allowed by Part 15 are:

- (1) Carrier-Current transmission through power lines
- (2) Direct Radiation by means of an antenna.

Although not specifically written into Part 15, a third method is allowed which is a combination of the first two. Transmission is allowed through a special coaxial cable (closed system like Carrier- Current) which is designed to "leak" radio waves (like that of an antenna). This results in a controlled radiation of signal to specific areas and over greater distances than would be allowed by the first two methods.

Radio field strength (intensity) is measured in volts per meter, millivolts per meter, and microvolts per meter. A volt per meter would be present if you measured 1 volt of radio frequency energy across a wire which is 1 meter in length while it is held above the ground. A simple voltmeter can not measure radio frequency energy accurately. Measurements are made with special equipment.

A standard broadcast station's primary coverage area involves two to ten millivolts per meter. Millivolts means THOUSANDTHS of a volt. Ten millivolts is the same as .01 volt. The allowed field strength radiated by a power line utilizing Carrier-Current transmission is limited to 15 micro-volts (15 MILLIONTHS of a volt). This is the same as .000015 volt! This is 1000 times LESS than a standard broadcast station is allowed. This low level of signal is comparable to electrical noise radiated by motors, fluorescent lights, microwave ovens, switches, etc.

This limitation is not easily met while still providing adequate coverage for your proposed audience. This is especially true for wooden frame buildings with unshielded power wiring. Wiring within conduit or concrete walls, and brick walls, reduces the radiation. Of course then portable radios won't receive the signal too well, if at all. Only those radios plugged into the power line could receive the signal. Of course power can be increased just to the point where radiation from the power lines is within legal limits. This would extend the range along the power lines and might provide some signal for the portable radios.

Part 15 of the FCC Rules specifies the maximum distance at which a field strength of 15 microvolts per meter is allowed. The distance is found by dividing 157,000 by the frequency in kilohertz. If you were to operate your station at 1000 kilohertz the distance would be $157,000/1000$, or 157 feet. This means 157 feet from any wire carrying your radio signal.

Another limiting factor set forth by Part 15 is the maximum RF voltage on the power line itself. It states "Low power communication devices obtaining their power from the lines of public utility systems shall limit the radio frequency voltage appearing on each power line to 200 microvolts or less on any frequency from 510 kHz to 1600 kHz. Measurements shall be made from each power line to ground both with the equipment grounded and with the equipment ungrounded."

OK! So maybe you should use an antenna just like regular broadcast stations. Just radiate directly in all directions! The Rules say that when you are connecting to an antenna that: (1) the antenna, including any coaxial cable and ground wire, must not exceed 10 feet in length, and (2) the total DC power input to the final stage of the transmitter shall not exceed 100 milliwatts. Either way you just barely get 15 microvolts at the specified distance, and then only under the best of conditions.

All this is not too encouraging. To top it all off the station shall; (1) cause no harmful interference to licensed stations, (2) keep harmonic or other spurious signals outside the broadcast band at least 20 dB below the carrier level (1/10th the voltage level, 1/100th the power level), and (3) obtain "certification" from a skilled "technician" that all these requirements have been met.

It is easy to see why most Carrier-Current and Low Power AM broadcasters operate only semi-legally or operate as a full-blown "bootleg" or "pirate" station. Before you decide how legal you want your operation to be, you should consider both sides of the coin.

The FCC has a massive job to do in policing marine radio, regular broadcast and TV stations, amateurs, the Citizen's Band, and a host of other operations. For this reason the field offices simply do not have enough time to go looking for someone violating the low power communication Rules. Even so, they are often aware of a station that has a little more range than it is supposed to have. If that station is not interfering with a licensed station; if the range is not a flagrant amount; and no one has complained about the station, the FCC field office tends to ignore them. Rest assured, however, the FCC will visit your station if they receive a complaint, or are aware of a flagrant violation such as miles of coverage, swearing on the air (another rule), etc. If you present a low profile and try to stay within the Rules you should have nothing to fear.

The least that can happen is an FCC engineer will pay you a visit. Usually the engineer will examine the equipment and make recommendations of how to correct your operation. These corrections would most likely be: (1) you must lower your power, (2) change frequency, (3) reduce interference outside of broadcast band, (4) obtain certification from a "skilled technician", (5) stop swearing or telling dirty stories on the air, etc. Of course the engineer will order you to shut down your station until you've made all the corrections. When all is in order and you are able to operate according to the Rules, you may go back on the air.

If you continue to broadcast after the FCC has ordered you to shut down, or you fail to make the corrections, you are looking for trouble. If you try to correct the problems, and are able to convince the inspector of this, but something is still wrong, then you'll probably just get another shut down order. If the FCC engineer thinks you are trying to fool him, or you have caused several people to file complaints, you may be shut down for good. If the violation of the Rules appears severe enough you could be ordered to pay a fine.

If you are determined to broadcast after repeated warnings - knowingly committing violations - you could be punished by means of a heavy fine. In rare cases, and usually only when all other methods of enforcement of the Rules has failed, the FCC can obtain a search and seizure order. The FCC engineer and a federal Marshall then pay you a visit and confiscate the offending equipment.

HOW TO SELECT YOUR FREQUENCY

Don't select a frequency for your station simply because you like the number. Several factors should first be considered. These include:

Interference received from, or given to, other stations

Harmful interference caused to stations outside the broadcast band

Fidelity and bandwidth

"Beat frequency" interference

Range and field strength limitations

Standard broadcast stations are spaced at 10 kilohertz (10,000 cycles) intervals across the band. The bandwidth of each licensed station is also 10 kilohertz. Bandwidth simply describes the total amount of radio frequency spectrum used by a station. The bandwidth includes sets of both lower and upper "side bands". Side bands are produced by the modulating action of the transmitter. Modulation combines the carrier frequency and the audio frequencies which produces these additional frequencies called sidebands. As an example, a 1000 cycle audio tone modulating a carrier frequency of 540 kilohertz (540,000 cycles) would produce two additional frequencies of 539 kilohertz (lower sideband) and 541 kilohertz (upper sideband). The total bandwidth required to transmit a 1 kHz (1000 Hz) audio tone is therefore 542 kHz - 539 kHz or 2 kHz (2000 Hz). In other words, the bandwidth is twice the audio modulating frequency. Since standard broadcast stations are limited to a 10 kilohertz band width, it follows that the highest audio frequency which can be transmitted is 5000 cycles. This is hardly "hi-fi".

As a Carrier-Current or Low Power (nonlicensed) station you are not bound by the 10 kilohertz Rule legally. You could modulate your transmitter with good 15,000 cycle hi-fi music. This would, of course, produce a total bandwidth of 30,000 cycles. Therein lays a two-fold problem. First of all a 30,000 cycle bandwidth would overlap the channel space of licensed stations on both sides of your frequency. This kind of interference would most certainly bring complaints, and, the FCC. Secondly, most AM radios are designed for reception of a 10 kilohertz bandwidth. The radio simply would not "hear" any audio frequencies above about 6,000 Hz. It would simply be a waste of time and effort trying to broadcast "hi-fi" sound.

It is also possible to select a frequency which is "between" regular channel allocations. Regular channels begin at 540 kilohertz and continue in 10 kilohertz intervals to 1600 kilohertz. Channels are 540, 550, 560, 570,.....1580, 1590, 1600 kilohertz. A "between" channel would be something like 545 kilohertz, or maybe 565 kilohertz. Selecting an in between channel is not good practice however for the following reasons.

A "beat frequency" could cause interference. A beat frequency is simply the result of two frequencies mixing together in a receiver. If there is a licensed station on either, or both, side(s) of your "between" channel several types of interference are produced. For example: Suppose you select 545 kHz as your station frequency and someone nearby tunes to their favorite station at 550 kHz. Their radio would not have enough selectivity to "tune-out" your 545 kHz signal - both would be received at the same time. The two frequencies would mix together in the receiver producing a "sum" of 1095 kHz and a "difference" of 5 kHz. The 1095 kilohertz may not be a problem, but the 5 kHz can be heard. The person listening to the 550 kHz station gets a 5,000 cycle whistle PLUS some of your music. This probably would cause the person to complain to the FCC. Best bet, use conventional channels.

Another matter to consider is the amount of radiation you wish, or can tolerate, from your transmission line. Where transmission is by way of a power line, all the radios plugged into that power line have a good chance to receive the station. Portable radios however must rely on whatever signal "leaks off" the power line. The distance at which reception is possible from a power line is limited by the maximum field strength allowed which is also dependent on frequency.

Frequencies at the lower end of the band do not leak off transmission lines as easily as higher frequencies. This is because of the longer wave length of the lower frequencies. The short runs of power line are simply too short to act as an efficient antenna. The result is that RF power can be increased to the transmission line to obtain greater ranges, and still stay within radiation limits. At a frequency of 540 kHz, the distance at which you are limited to 15 microvolts per meter of field strength is about 300 feet. At a frequency of 1600 kilohertz the distance is about 100 feet.

Another advantage is that most AM radios have better selectivity at the lower frequencies, thus your weak signal easier to find. Night time "skywave" interference from distant stations is also minimized when operating at the lower frequencies.

It appears that selecting a frequency at the low end of the band would solve most of your problems. There is at least one problem however with frequencies below about 800 kilohertz. The problem is second harmonic interference. The second harmonic is simply the frequency which is twice the carrier frequency. If you chose 600 kilohertz as your operating frequency, the second harmonic would be 1200 kilohertz. You may never have a problem with your second harmonic, but there is a chance. This second harmonic could be strong enough to cause interference to a licensed station and bring in some complaints. By selecting an operating frequency above 800 kilohertz you would put the second harmonic outside the broadcast band. You would still have to be careful that your second harmonic does not interfere with a Public Safety Radio Service station. Some of these stations are licensed to operate just above the standard broadcast band.

The second harmonic frequency is sometimes hard to eliminate. It can be generated by the transmitter itself or anywhere on the transmission line. The output of the transmitter can be filtered with a device called a "second harmonic trap" but that still leaves the transmission line to contend with. A coaxial transmission line usually will not generate second harmonics. It takes a non-linear device to generate second harmonics. About the only non-linear device on a coaxial transmission line would be a very dirty or oxidized coax connector. Power lines have many non-linear devices attached however. Some of these are: fluorescent lights, motors, light dimmers, loose incandescent lights, dirty switches, and even loose connections and splices.

Electrical noises will always be a problem for anyone tuning-in your station, simply because of the limit placed on your field strength. Radiation by antenna and reception by antenna is moderately prone to interference from electrical noises. Carrier-Current transmission over coaxial cable is perhaps the most free of noises. The power line transmission (true Carrier-Current) is the most susceptible to electrical noise. Fortunately electrical noises tend to "group" at various spots on the band. Because of this it is sometimes possible to find a frequency which is relatively quiet, even when reception is over the power line.

We can conclude from this information that a frequency should be selected on the basis that: (1) it is a regular channel frequency (2) it is at the low end of the band (3) its second harmonic will not cause interference to a licensed station (4) it is located at a relatively low noise portion of the band.

The next step is the actual determination of the best frequency to use.

LOCATING AN OPERATING FREQUENCY

A great deal of engineering goes into a frequency search for a licensed station. Fortunately a C-C station is less complicated. You won't have to worry about ground conductivity charts, exact channel allocations, output power of local stations, skywave interference projections, and the like. All you will need is a good AM receiver and know your way around the inside of it. If you're not sure about getting inside the radio you'll need some help from a technician or a amateur radio operator. Better yet, borrow a "communications receiver" which can tune the broadcast band.

A communications receiver has provisions for adjusting its sensitivity and for disabling the AVC. The AVC action (automatic volume control) in a regular radio makes all received signals look like they have about the same field strength. What we want to do is tune the entire band slowly and make a chart showing the relative field strength of each station received. We will also want to show the relative noise levels across the entire broadcast band. Remember, you can't rely on what you hear from the speaker. Unless the receiver's AVC circuit is disabled all stations will sound about the same loudness.

The receiver should be highly selective, have a good dial resolution, and be fairly sensitive. Communications type receivers often have an "S" - meter which shows relative signal strength. If an ordinary consumer type radio is used then a meter must be connected to a point called the AVC line or bus. This is not easy to do if you are unfamiliar with the workings of a radio. A vacuum tube voltmeter, or the solid state equivalent - the FET meter, is connected to the AVC bus of tube type radios. These types of test meters also have provisions for measuring current. The meter would be switched to measure microamps of current when connected to the AVC bus of a transistorized radio. Don't try to do this yourself unless you know for sure what you are doing. You could be severely hurt by electric shock if you touch the wrong spots inside an AC powered radio. Meters connected to the AVC bus should read up-scale when a signal is received. The higher the reading, the stronger the station's signal.

The radio should have provisions for connecting an outside antenna. The antenna wire should be at least 30 feet long. Radios with loop antennas (built-in antennas) are too directional. You would have to continually turn the radio trying to find the highest possible signal strength for each station received. This is unnecessary extra work. The long-wire antenna is your best bet. If the radio has a ground terminal ground it.

Slowly sweep the broadcast band from one end to the other. Draw a bar type graph similar to the following example. Show the relative signal strength of each received station. After plotting each station's signal you should sweep the band again and plot the relative noise levels. The noise level check may have to be done when some stations are off the air.

If the majority of your listeners will have their radios plugged into the wall socket (Carrier-Current reception) then you should do your noise tests with the power line in mind. A good indication of power line noises can be obtained by running about 6 feet of extension cord along your test receiver's antenna wire. The other end of the cord is plugged into the wall socket. This brings the power line noises right to the antenna terminals of your test receiver.

Some licensed stations are required to shut down after sunset. This is because skywave interference becomes greater at night. Of course, the stations allowed to stay on the air at night gain additional range. Another fact to consider is the differences in electrical noises during the day and night. For these reasons at least three separate charts (graphs) should be prepared.

One graph should be prepared in the early morning hours to catch stations that come in by skywave. Another test is made during midday to check the "daytime only" stations. The third test is made during the night since skywave reception can vary greatly between sunset and sunrise. All three sweeps of the band should be done again after several days, just to verify the results. Measurements during the fall, spring, and winter months are usually the most reliable.

Analysis of the following sample graph seems to indicate at least 4 good channels. These are at 600, 650, 1260 and 1200 kilohertz. To be safe, we should determine which of these is the most suitable.

The channel at 1260 kilohertz appears to have a low noise level and no stations were detected at 1250 and 1270 kilohertz. This might be a good choice except for one thing. Occasionally a strong buzzing sound can be heard around the 1252 kilohertz. It's not there all the time, just enough that it might be annoying to your listeners. Receivers without sharp tuning characteristics might have difficulty tuning-out the buzz. This channel then is only a fair choice.

LOCATING AN OPERATING FREQUENCY

The channel at 1290 kilohertz also has a nice low noise level but it also has a very strong adjacent channel station. Most likely your listeners would have a difficult time tuning-out the stronger station. This would be a poor choice.

The channel at 650 kilohertz has only a fair noise level, but perhaps low enough to be acceptable. The two adjacent channels have quite weak signal levels, almost not receivable. Before accepting this channel however we should look at possible second harmonic interference. Your second harmonic would be at 1300 kilohertz. Luckily the station on 1300 kilohertz puts in a very strong signal. The chances of your weak second harmonic causing interference to them is quite small. It appears that 650 kilohertz would be the best channel to use according to our sample graph.

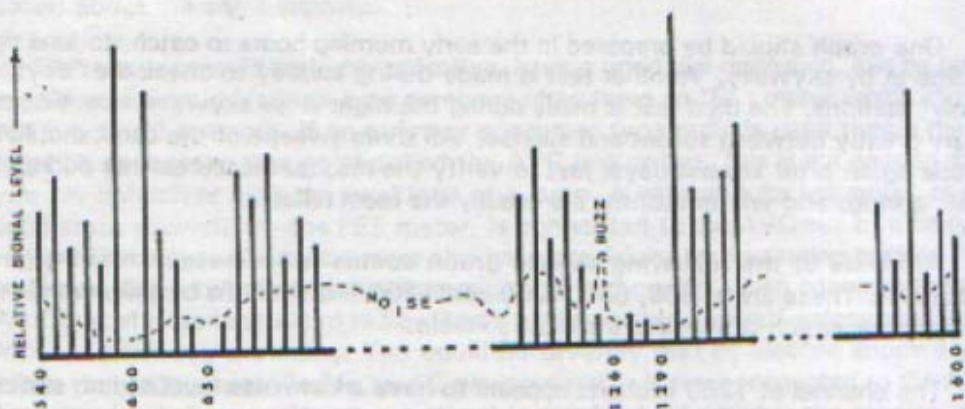

RF DISTRIBUTION SYSTEMS

The method by which you'll get the signal from your transmitter to your audience depends on several factors. These factors differ from one physical, or geographical location to another. Some of these factors will be discussed as different methods of transmission are described. But, to give you some idea of what you must consider, some of these factors are:

AREA TO BE COVERED
LOCATIONS OF POWER TRANSFORMERS
AVAILABLE ELECTRICAL WIRING
STRUCTURAL MATERIALS OF BUILDINGS
RURAL OR METROPOLITAN AREA
NATURE OF TERRAIN
AMOUNT OF MONEY YOU CAN SPEND

Distribution of your signal can be accomplished by one, or by several different methods. The method, or methods, you choose must be considered in view of your particular location, conditions, money available and how legal you wish your operation to be. A general description of distribution methods follows:

CARRIER-CURRENT: Your RF signal is fed into electrical power wiring. Radios connected directly to the power line and portable radios within 200 to 300 feet receive your signal.

DIRECT RADIATION: Your RF signal is radiated from a short antenna. All AM radios within a 200 to 300 foot radius should receive your signal. Illegal operation could extend the range to several miles and is not permitted by Part 15.

INDUCTION: Your RF signal is fed into a "leaky" coaxial cable. The cable may run along hallways, around a campus, or be buried underground a few inches. AM radios within 200 to 300 feet of the cable should receive OK.

REPEATERS: Small transmitters or amplifiers are placed at specified locations. Repeaters are connected to the main transmitter by means of a coaxial cable. Coverage area of each repeater may be served by any or all of the other distribution methods listed. Signal strength at any point where transmitter or repeater coverage overlaps must not exceed that prescribed by Part 15.

CARRIER-CURRENT DISTRIBUTION

To operate most efficiently a transmitter must be "matched" to its "load". The load in a general sense is an antenna or a transmission line such as a coaxial cable. A perfect antenna presents a purely "resistive" load to the transmitter. A purely resistive load uses all the energy fed to it by the transmitter. This is the most desirable of conditions. A purely resistive load is rarely found in actual practice however. Instead we must deal with a characteristic called "impedance".

Impedance is a combination of resistance and another characteristic called "reactance". Reactance is a term only applicable to AC circuits. Both Radio Frequency and the power line frequency are "AC". We must consider these reactances when feeding energy into the power line, other wires, coaxial cable, and even antennas.

Reactance may be either "inductive" or "capacitive". A length of wire is inductive. A motor is inductive. Transformers are inductive. Wires enclosed within a metal conduit appear somewhat capacitive. Capacitance is exhibited between the windings of a transformer. Certain lighting controls can appear capacitive. In other words, an AC power line is full of different reactance producing devices. To make matters worse, some devices react differently at different frequencies. At 60 Hz transformers are mostly inductive, but at radio frequencies they become capacitive.

The impedance also changes between day and night. Kitchen appliances, TV's, lights, air conditioners, electric heaters, etc., all add to the confusion. These changes are likely to be more dramatic near large industrial complexes and heavily populated residential areas. Fortunately a well designed transmitter or line coupling unit can "tune-out" most of the reactance problem. Matching to the line impedance will be discussed under "coupling methods".

AC power line distribution transformers pose another problem. High voltage feed systems, operating at about 4000, 12,000 or 22,000 volts, are stepped down by transformers to the more familiar 220 and 117 volts. These step-down transformers are equipped with electrostatic shields which block radio frequencies. This usually means your signal stops at the first transformer. To distribute your signal along the power lines on the other side of the transformer requires another coupling point. A coaxial cable from the main transmitter, or from a repeater amplifier, would have to be coupled to the "service" side of each such transformer. The service side would be the side connected to the relatively low voltage lines of 220 or 117 volts.

Although it might be possible to couple your signal from one side of a power transformer to the other, it is not practical. Coupling capacitors would have to be installed between the input and output sides of the transformer. The voltage ratings of the capacitors would have to exceed the highest voltage present. This could be as much as 22,000 volts. Capacitors capable of withstanding that much voltage are quite expensive. Not only that, the power utility company wouldn't let you do it yourself (too dangerous) and probably wouldn't do it for you.

SYSTEM LAYOUT

Perhaps the best method is to centralize the transmitter and run low-loss coaxial feed lines to each coverage area. The simplest system would consist of coupling directly into the power line as close to the transmitter as possible. Where a transformer would interfere with distribution a feed line would be needed to connect to the other power lines.

Multiple transmitters could be used but this sometimes causes a problem of "beat frequency interference". A beat frequency is caused when two transmitters of about the same frequency are received by the same receiver. A difference of only a few cycles (Hz) between the two frequencies might sound like a flutter at the receiver. As the difference between frequencies becomes greater the receiver hears a tone. The tone would be constant in volume and pitch and would be present all the time. Of course this would be highly annoying. It is for that reason that one master transmitter is suggested. If more power is needed at some distant location a repeater amplifier should be used. All repeaters would broadcast on the same frequency as the master transmitter and therefore could not cause interference.

Where extreme distances between transmitter and intended coverage area exist multiple transmitter operation might be necessary. This would be the case where the length of coaxial cable is just too lossy (very little power getting to coverage area) or the expense becomes too great. Each transmitter is controlled and coupled separately. Each transmitter is fed audio signals however from the same studio. Provisions should be made to keep each transmitter on the same frequency, or that distance between them is great enough to avoid interference. Another case where multiple transmitter may be required is where no practical path for a coaxial cable exists between coverage areas. It is sometimes difficult to get permission from utility companies to use their poles. And, ducts in buildings and underground burial may not be available either.

Several techniques may be necessary to complete your Carrier-Current system. Only you, or someone who does consulting work in this area, can determine which techniques fit your needs best. A few system examples are outline below. Any of all of these may be necessary for your particular location and conditions.

C = coupler	Solid line - service-line (220/117 v)
P = power splitter	Dashed line = high tension line (12,000 v)
X = transmitter	Dotted line = coaxial cable
T = power transformer	Dot-Dash line = audio line

Fig. 1 represents a neighborhood of a few homes. All the homes in row "A" are fed by a common power transformer. The homes in rows "B", "C", and "D" also have a separate transformer for each row of homes. The "X" home is the location of the transmitter.

All the homes in row "B" would receive the radio signal OK. It is doubtful that row "C" would receive a usable signal. Row "D" would not receive a usable signal. Row "A" on the other hand is just across the street, a distance of perhaps 100 feet. The chances are very good that some signal will be radiated from the power lines connected to row "B" and will be picked up by the homes in row "A". If the distance between row "B" and "C" homes is between 100 and 200 feet then row "C" might get some usable signal.

If the backyard neighbor of row "C" is agreeable, a coaxial cable can be run between homes, a repeater-amplifier-coupler can be installed, and signals can be fed to the power lines of row "C". All of row "C" would then receive signals OK. Row "D" is just across the street and would pick up the radiation from power lines. Under the right conditions signals radiated by rows "B" and "C" can reinforce one another and extend coverage another block or two (row before "A" and row "E")

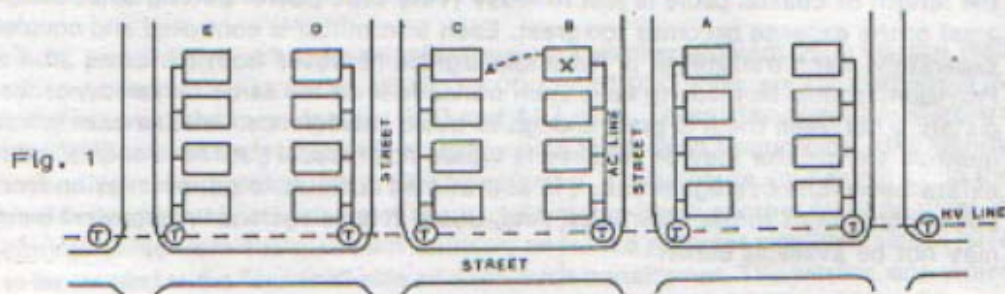

Fig. 2 represents a campus setting. The transmitter is located at a centralized point and feeds the service power line. The other buildings on campus share the same power transformer (same power line). This is the simplest and best set of conditions. All buildings receive the signal well.

Fig. 3 represents a similar campus setting. In this case however the electrical loads are such that a separate power transformer is needed for each building. Transmission over the power lines is therefore impossible. A coaxial cable is run between the transmitter and a point close to the other buildings. The signal is separated by a power splitter with a separate coax cable running off to each of three couplers. This way each building is fed the signal on the service side of the building's transformer. The couplers can be replaced with repeater-amplifiers if the power reaching the building is insufficient for good reception. For that matter, if the length of the coax from transmitter to the power splitter is very long, an amplifier can be installed just before the splitter. Since all the amplifiers are fed from a master transmitter there would be no problem with beat frequency interference.

Fig. 4 represents a campus where buildings are quite some distance apart. Signals from the master transmitter are fed to the first building's amplifier and power splitter. A small amount of the output from that amplifier is fed to the second building's amplifier and power splitter. The third building's amplifier is fed from the second building's splitter. This is very much like a cable TV system where booster amplifiers are used for neighborhood distribution.

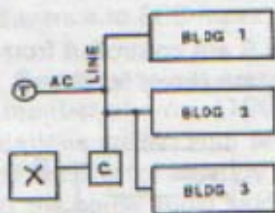

Fig. 2

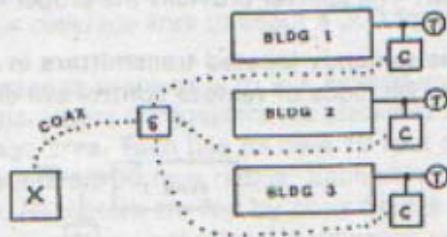

Fig. 3



Fig. 4

Fig. 5 represents a multiple transmitter system. In this case the buildings are far enough away from the proposed studio that coaxial cable must be ruled out. The expense of the cable may be too great, or there simply isn't a convenient way to get the coax from the studio-located transmitter to the desired buildings. Since a master transmitter can not be used, several smaller transmitters are used instead. Each of these transmitters services a particular building but each is fed audio from a special telephone line. Several grades of telephone lines are available. The different grades will be discussed in a different chapter.

The transmitters of figure 5 may be operated on the same frequency or may be staggered in frequency. If the buildings are more than about 300 feet apart then different transmitter frequencies should not cause a beat frequency interference problem. One transmitter might be at 640 kilohertz, another at 650 kilohertz, and the last at 660 kilohertz. Caution must be observed however that the frequencies chosen would not cause interference to the reception of a licensed radio station.

Fig. 6 is a combination of the systems described in figures 3 and 5. The distance between the studio and the first building prohibits the use of coaxial cable but can accommodate audio by telephone line. The distances between buildings served however is close enough to make a coaxial cable practical. In this case only one transmitter is needed. It is located in the first building and is followed by a power splitter. The splitter provides the proper amount of power to each of the buildings.

The remotely located transmitters in systems 5 and 6 are controlled from the studio. Methods of remote control are discussed under "telephone facilities".

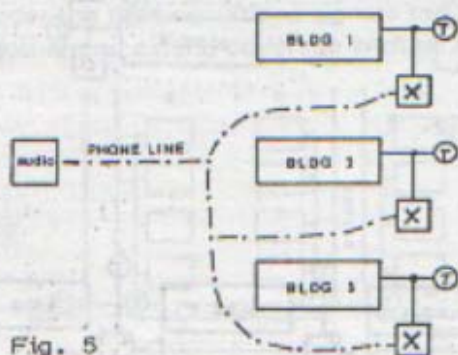

Fig. 5

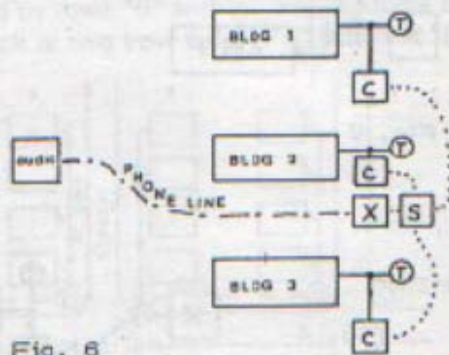

Fig. 6

DIRECT RADIATION

Direct radiation of your signal requires some sort of antenna. To be most effective an antenna must be of a specified length. When speaking of vertical antennas, those used in AM broadcasting, the length means the same as its height. Antennas are normally a multiple of one quarter wave-length. The wavelength is found by dividing the speed of light (300,000,000 meters per second) by the transmitted frequency. If you wanted an antenna for 600 kilohertz your calculations would reveal: $300,000,000/600,000$ equals 500 meters. A quarter-wave length would be $500/4$ or 125 meters in height.

An antenna 125 meters in height is high! The physical height (length) of an antenna can be reduced by adding a coil of wire to its feed end. This is called a loading coil. Although a 125 meter antenna could be reduced in height to only 50 meters, and thereby still match the transmitter, its overall efficiency suffers. In other words, the shorter an antenna, the lesser the coverage area.

Of course an antenna 50 meters high is out of the question unless you have several thousand dollars to spend. For low-power AM broadcasting the FCC wouldn't allow it anyway. Remember, as discussed earlier, the FCC Rules state the maximum length of the antenna can not exceed 3 meters (10 feet), including the transmission line. A single, 10 foot antenna, does not radiate too well. Strict adherence to FCC Rules should limit your coverage area to about a 300 foot radius.

One way to get around the short antenna problem is to use several antennas! A number of small (100 milliwatt) transmitters or repeaters are placed at specific locations within your proposed coverage area. Each has its own 10 foot antenna and is therefore legal by itself. Each covers a 300 foot radius. Each transmitter is fed the same audio signal by wire line. Repeaters are fed by coax from a master transmitter. Fig. 7 shows how this can increase your effective coverage area.

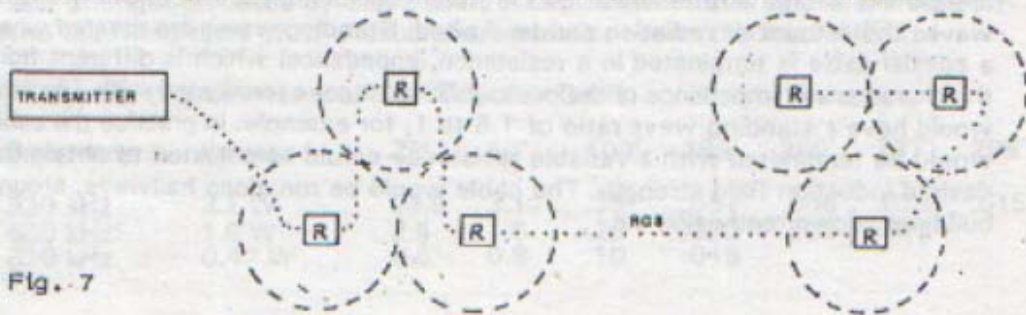

Fig. 7

TRANSMISSION BY INDUCTION

Induction is the term used to describe "near field" radiation. There are actually two types of radiation by an antenna. The first, which has a very strong field near the antenna, is called the induction field. The strength of this field decreases as the "cube" of the distance. In other words, every time the distance from the antenna is doubled, the field strength is 1/8th as great. If the distance is tripled the field strength is 1/27th as great.

The second form of radiation is the "far field" or "radiation field" which does not change in strength as drastically as the "near field" radiation. The far field radiation decreases in strength as the inverse square of the distance. In other words, if the distance from the antenna is doubled, the field strength is reduced to 1/4th. At four times the distance the field strength is reduced to 1/16th.

At a certain distance from the antenna the near field and far field are equal. Up to that point the near field's strength is predominate. Past that point the near field's strength drops off rapidly and the far field strength is predominate. It is at this distance from the antenna that the FCC has set the limit of 15 microvolts per meter. This distance = $157,000/\text{Frequency (in kHz)}$.

All this means that radios close to an antenna will receive a very strong signal. This makes it possible to simply feed RF energy into a very long wire, which in turn provides a near field radiation usable by nearby radios. Long wire antennas however are somewhat unpredictable. Dependent on placement and length, the far field radiation may be excessive and beyond the distance limitations. For this reason long wires run around buildings, down hallways, and along roads, is not recommended. There are more controllable methods.

A coaxial cable, when properly terminated, leaks very little radio frequency energy. By creating a condition called "standing waves" the coax can be made to radiate like a long wire antenna. By carefully controlling the amount of standing waves the amount of radiation can be limited. Standing waves are created when a coaxial cable is terminated in a resistance (impedance) which is different from the characteristic impedance of the coax. A 50 ohm coax terminated with 75 ohms would have a standing wave ratio of 1.5 to 1, for example. In practice the cable would be terminated with a variable resistance would be adjusted to obtain the desired induction field strength. The cable would be run along hallways, around buildings, down roadways, etc.

Unfortunately standing waves on a transmission line (coax) presents an improper load to the transmitter. A special coupling network would be needed to properly match the transmitter to the coaxial cable. A special cable has been developed however which will present a proper load to the transmitter.

This special cable is manufactured by LOCRAD and designed to be "leaky". In other words, it is designed to radiate slightly even when terminated with the proper load impedance (50 ohms). Two sizes are available. The NF-1 cable is approximately the same diameter as the RG 59 cable used by cable TV companies. This is quite convenient because you can use common TV cable fittings and accessories during installation. The NF-2 cable has a somewhat larger diameter with a resultant lower loss characteristic. The NF-1 is recommended where the system's total cable length is less than 2,000 to 2,500 feet. Where the total cable length is expected to be greater than 2,500 feet but less than 5,000 feet, the NF-2 is recommended. See the "Sources" section for cable suppliers.

A typical installation would keep cable lengths to a minimum to minimize losses. The output of the transmitter is first fed to a power splitter which in turn feeds power to several short cable branches. Fig. 8 shows a typical installation.

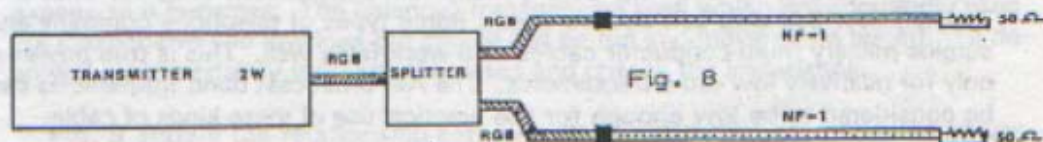

The maximum distance at which 15 microvolts per meter field strength may be present is determined by the operating frequency. The higher the frequency, the shorter the distance. The field strength must therefore be reduced to match the shorter distance. In other words, the power fed to each induction cable, and the field strength produced by that power, is dependent on the operating frequency. The following table of NF-1 cable characteristics shows this relationship.

Typical Characteristics of NF-1 Induction Cable

Frequency	Power	25'	50'	100'	189'	200'	237'	296'
530 kHz	2.1 W	24.9	3.1	.39	.057	.048	.029	.015
660 kHz	1.6 W	2.8	1.6	.20	.030	.025	.015	
830 kHz	0.47 W	6.5	0.8	.10	.015			

TRANSMISSION LINES

A transmission line is simply a pair of wires used to move your radio signals from one place to another. Your radio signals may be transmitted along the wires from your transmitter to an antenna, an induction cable, a power splitter, a repeater-amplifier, etc. Generally, the transmission line itself should not radiate.

Two wires running parallel to each other at a fixed distance between them is often referred to as "twin lead". This type of transmission line is said to be "balanced" since neither wire is ever grounded. Two wires which are twisted together are called a "twisted pair". A twisted pair is a balanced transmission line.

A two wire, balanced, transmission line has opposing currents flowing in each of the wires. These opposing currents tend to cancel any radiation that would otherwise result from current flowing in a wire. In other words, a properly balanced and terminated transmission line should not radiate.

It is sometimes possible to use a wire cable or group of wires as a balanced transmission line even though it was not intended for that purpose. Ordinary extension cord wire, and "zip cord", make fair transmission lines for example. Twisted door bell wire can also be used. Some types of telephone company and surplus military multi-conductor cables also work fairly well. This is true however only for relatively low radio frequencies. The AM broadcast band frequencies can be considered to be low enough for the practical use of these kinds of cable.

The balanced transmission line is important because there will be some Carrier-Current and low power AM installations where it is impossible to run coaxial cable. Very often however these installation sites already have some form of wiring, such as an unused intercom system, unused telephone lines, door bell circuits, etc. Another factor is that these cables are often cheaper than coaxial cable. Some of them can be found at surplus stores, and in the case of schools, at "educational surplus warehouses".

The only problems encountered with odd types of wire cables used as a balanced transmission line is not knowing the characteristics. It is almost impossible to predict the impedance of such a line for example. Another factor is the loss of the cable - how much power is actually transmitted? And, because the cable is balanced, it requires matching to the transmitter which is usually equipped with an unbalanced output. Where practical and within your budget you should always first consider using coaxial cable.

Coaxial cable also consists of two wires. In this case however, the outer conductor (called the shield) shields the inner conductor. The outer conductor is usually grounded. When terminated in the proper impedance the coaxial cable will not radiate. Because the outer conductor is grounded the cable is said to be unbalanced. The impedance and loss factors of all manufactured coaxial cables is well documented.

Coaxial cables are made with different diameters, insulating materials, and types of wire, all of which affect the cable's impedance, power loss, and velocity factor. Normally in Carrier-Current and low power AM installation the velocity factor is of little importance. The impedance and the power loss characteristics however must be considered in the design of the system. The power handling limits of most coaxial cables used as transmission lines for AM broadcast frequencies is far in excess of that needed for Carrier-Current installation. Even the smallest cable, RG58, can safely handle 800 watts of power.

Appendices A and B should be compared to gain a better understanding of the power losses and costs involved between balanced pairs and coaxial cable. The coaxial cables are the least lossy, have the most stable impedance but cost the most. The larger the diameter of the coaxial cable the less the loss but the more expensive it becomes. The balanced transmission lines which are commonly used are inexpensive and low loss but should not be run in conduit or be buried. To do so will most certainly increase the losses and change the impedance.

Fig. 9 shows the relationship between dB loss and the percentage of power remaining at the end of a cable run. As an example: Assume you have a cable run of 225 feet. You use RG-58 which has a loss of .443 dB per 100 feet, at 1000 kHz (Your operating frequency is 1000 kHz). 225 feet divided by 100 feet = 2.25 and $2.25 \times .443 \text{ dB} = \text{total loss of } .996 \text{ dB}$. Fig. 9 shows about 80% of the power delivered to the cable is present at the end of the cable run.

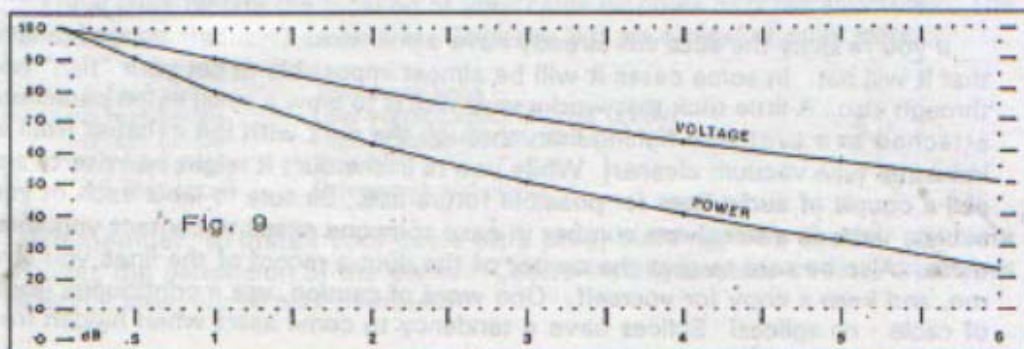

TRANSMISSION LINE INSTALLATION

Where to run the cable is often a problem. How does one get a cable from one building to another, 100 feet away, on the other side of a paved road or parking lot? Dig trenches in the concrete? Stretch the cable between power poles?

The above options are limited to a great extent by who owns the road and the power poles. If the road is owned by a public agency such as the county, city or State, forget about digging a trench. You may have a chance if the road or poles are privately owned or owned by a school or college.

Installation of cables within buildings, and between buildings which have common services is much easier. Common services means electrical power from the same transformers, telephones, heating and air conditioning, etc.

Often there are ducts between buildings for the purpose of running telephone cables. This is especially true on school and college campus'. The ducts are school property. The telephone company however may act as if you have no right to use "their" cabling ducts. Diplomacy will go a long way to making your installation easier if you want to use these ducts. A long steel "fish" wire with a 1" ball on the end is fed into one end of the duct. Some ducts can be up to 300 feet long, be sure your wire is long enough. When the ball comes out the other end, simply attach your cable and pull it back through. The use of a lubricant such as soap or wax will help the cable slide better. It would be wise to also run a "pull wire" in case you want to run more cables at a later date. The pull wire can be left in the duct permanently but should be of a material that won't rust or rot. Copper wire (heavy) or nylon rope is good for this purpose.

If you're lucky the duct will already have a pull wire. The chances are however that it will not. In some cases it will be almost impossible to get your "fish" wire through also. A little trick that works very well is to blow a small nylon parachute, attached to a synthetic fishing line, through the duct with the exhaust from an industrial type vacuum cleaner! While you're in the duct it might be wise to also pull a couple of audio lines for possible future use. Be sure to label each of your cables. Include a telephone number in case someone needs to contact you about them. Also be sure to give the owner of the duct a record of the lines you have run, and keep a copy for yourself. One word of caution, use a continuous length of cable - no splices! Splices have a tendency to come apart when hidden from view!

Running cables in heating and air conditioning ducts requires only a few simple precautions. In heating ducts the temperature can make some wire insulations dry and brittle so they eventually crack. In very hot ducts the polyethylene type coaxial cables develop "flow" of the inner conductors insulation. Sharp bends or kinks in the cable allows this "flow" to move away from the inner conductor. The result is a change in impedance at that point and a possible shorting-out of the inner conductor to the shield. Where possible, cables should be run at the bottom of heating ducts where the temperature is lowest. Air conditioning ducts might present some moisture problems at times. Cables should be moisture proofed.

Some cables are designed for direct burial. Specially sheathed versions of CATV cable are available for this use. Another prospect is to bury a length of plastic pipe or tubing. The plastic tubing used for "drip irrigation" systems is relatively inexpensive. Simply run your cable through the tubing, remembering however, moisture may be a problem. Always protect the open ends of the tubing or pipe from direct water entry such as rain. Also, be sure the pipe or tubing is deep enough to protect it from future encounters with shovels and Rototillers.

The last resort is overhead installations. Cables hung from pole to pole are susceptible to all kinds of damage. The weathering of cable by sun, wind, and snow or rain, can make it completely unusable in just a few years. Cables hung from poles or trees should have a built in "messenger" wire. This is a steel wire designed to take the weight of the hanging cable and avoids the stretching of the cable itself. CATV-type cables are available with a built-in messenger wire.

If you must use trees for support, leave enough slack or install a spring buffer in the messenger line. Swaying trees can snap even a steel wire. Be sure to ground the coax shield at several points to protect it, and the rest of your equipment, from lightning strikes and possible power line cross overs.

Local laws dictate the location of your cable on poles or other structures. The following are the requirements for California but are typical of other states:

1 foot above	Telephone lines
2 feet below	Low voltage electric lines (220v)
6 feet below	High voltage electric lines
18 feet above	Streets
15 feet above	Driveways and alleys

Remember, to install your cable on a pole, building, tree or other structure requires the permission of the owner. Cables installed across streets, driveways or alleys also require prior permission.

TRANSMITTERS AND REPEATERS

Exciter An exciter contains at least four distinct circuit functions. These include the oscillator (and buffer), a radio frequency amplifier, and audio amplifier-modulator, and a power supply. The output of an exciter is normally a low RF power. In all other respects it functions as a transmitter.

Power Amplifier A power amplifier increases a small amount of input RF power to a much larger output power. When used to amplify an already modulated AM signal it must do so without distortion. An amplifier that can faithfully reproduce its input signal while increasing power is said to be a "linear amplifier".

Repeater A repeater is a linear amplifier. It is designed to accept low power inputs which are already modulated and provide an increase in that power. It is used at the end of a long run of transmission line to boost signal levels up to a usable value.

Transmitter An exciter can be used as a transmitter but usually provides a low output level. When followed by a linear amplifier the entire circuit becomes a transmitter with a greater output power level. Monitoring meters are included to facilitate tuning and other adjustments.

Commercial carrier-current and low power AM equipment is somewhat limited to two manufacturers. Several companies have entered into the field but have dropped out of sight for one reason or another. The two which are active now are LPB, Inc. in Frazier, PA and Radio Systems, Inc. in Edgemont, PA.

AM transmitters are no longer very valuable on the amateur radio market. Most amateurs that once worked the lower frequencies have gone on to single side bands or other bands. Some of this ham equipment can be adapted to low power AM and carrier-current use. The operating frequency of the transmitter would have to be lowered for use in the broadcast band. An old 160 meter (1.8 MHz) transmitter should be fairly easy to modify. If you are not familiar with transmitters however you should find a sympathetic radio amateur to help you out.

Checking with old established AM broadcast stations can sometimes turn up a retired old transmitter. A 100, 250, or even 500 watt transmitter can be operated at reduced power to serve your needs. One of these old broadcast units will work quite well for a large campus, drive-in theatre, or an apartment house's coaxial fed distribution system.

Another source of AM transmitting equipment is the surplus market. You'd be surprised at how many different transmitters have been dumped by the Army and Navy. On some occasions you can find a transmitter in its original shipping case - never used!

The surplus transmitters were not designed for the AM broadcast band however. They have made transmitters for both below and above the band. Most times these can be modified by changing some of the tuning coils or capacitors to retune it to the broadcast band. Again, a radio amateur can be of great help if you yourself are not familiar with the circuitry. See the "Source" section for more detail.

For several reasons you may wish to build your transmitting equipment yourself. If you have some electronics background you should have no problem. If not, locate a radio amateur to assist you. The following schematic diagrams and discussion should provide you with transmission equipment suitable for a small to medium size system. The 100 mW exciter-transmitter is suitable for direct radiation systems. When used in conjunction with a 5 watt linear amplifier-repeater the combination becomes a 5 watt transmitter. The 5 watt linear amplifier-repeater can also be used by itself as a remotely located repeater or booster amplifier.

The Exciter

Fig. 10 shows all the circuitry necessary for a 100 mW AM exciter-transmitter with exception of the power supply. The unit is completely solid state for long term reliability and stability. Metering is optional but is recommended for ease of adjustment of the exciter and transmitter. The unit incorporates "negative peak loading" to reduce the possibility of "splatter" produced by overmodulating. The unit does not contain audio frequency processing however. Audio frequency processing is best performed before it is fed to the transmitter. Some transmitters incorporate audio low pass filters to limit the upper frequency response to about 6000 Hz. This is necessary where band width is limited by crowded band conditions. It has been purposely left out of this unit for individuals that wish to experiment with a greater band width. A "roll-off" control is included however to attenuate some of the higher audio frequencies.

Fig. 10 Circuit Description

The oscillator is designed around a low current CMOS integrated circuit, a CD4001A. The CD4001A is normally used as a quad - 2 input - nor gate. Its high input impedance and low current drain makes it quite suitable for a stable oscillator. The 4 - 40 picofarad trimmer capacitor allows fine adjustment of the crystal frequency. The output from the oscillator is isolated from the rest of the transmitter by a buffer amplifier. The buffer amplifier is an inverting amplifier made by connecting the 2 inputs of the second nor gate together and driving it with the oscillator.

The output of the buffer is a square wave at the crystal frequency. The RF amplifier may be fed directly from the buffer or a frequency divider stage may be included. The frequency divider stage is used where extreme frequency stability is desired.

The frequency divider consists of an MC 74LS90 strapped to divide by 10 and give a symmetrical output, also a square wave. In this case the crystal frequency must be 10 times the desired operating frequency. If you choose 640 kHz as the operating frequency, the crystal frequency would be 6.4 megahertz.

The output of the buffer, or the divider, is fed to the RF amplifier through a 22 picofarad ceramic capacitor. The RF amplifier is both base biased and emitter biased for protection and stability. The slight positive bias as the emitter effectively allows the transistor to fully turn off when the emitter voltage of Q2 falls below about 2 volts. This assures 100% modulation during negative audio swings. The base bias is derived from the modulated collector voltage to assure adequate drive and 100% modulation during positive audio swings.

The collector is tapped at 25 turns of the amplifier tank coil. A compression type trimmer capacitor is used to tune the tank to the proper frequency. The trimmer is connected across the entire tank coil. This method reduces tank circulation currents, provides impedance matching to the transistor, and improves waveform (reduces harmonic content). Output for an antenna, amplifier, or transmission line is taken from a 10-turn link. The tank coil is made from an ARCHER 273-102, 100 microhenry RF choke. Twenty-five turns are carefully unwrapped from the choke, a tap made, and the turns replaced. The link is simply 10 turns of #22 enamel or varnished magnet wire wound at the opposite end of the choke from the 25 turn tap. The output is monitored by a meter when the unit is used as a transmitter. The meter is optional but aids greatly in tuning.

An LM 741 operational amplifier is used to set both the DC level and to supply the audio modulation. Its output is fed to Q2, the series modulator. The gain of the LM 741 is set at about 40. This means about 1 volt peak-to-peak at the input will drive the transmitter to 100% modulation. A 1 volt peak-to-peak audio signal, at 600 ohms, represents about -6dBm. The input network, which includes a modulation control and peak limiter control is shunted with a 750 ohm resistor. The whole network appears as about 600 ohms. 600 ohms is a standard broadcast impedance in audio work.

0 dBm input, about 2.2 volts peak-to-peak is a normal reference level. An input of 0 dBm allows use to the peak loading portion of the input circuit. The effective reduction of the negative going peak of the audio modulating the RF amplifier reduces overmodulation clipping. Since the LM 741 is fed audio at its inverting input, the loading diode actually works form the positive going input peaks. Below about 2 volts peak-to-peak no loading occurs. Any voltage above 1 volt peak on the positive audio swing causes the diode to conduct. Part of the positive input peak is lost in the series input resistance. The output of the amplifier sees this as a smaller negative going peak. The amount of loading is adjusted by the 10,000 ohm control. At maximum resistance the negative modulation peaks are reduced about 25%.

Any good general purpose or RF transistor of the NPN type may be used for Q1 and Q2. The transistors should have a power dissipation rating of 300 milliwatts or more, a VCBO rating of 40 volts or more, a current gain of 50 or better, and a frequency of up to 20 MHz. Some good types are the 2N3904, RS2009 and RS2012 (Radio Shack).

If desired a VU meter may be connected to the output of the amplifier through a DC blocking capacitor and a series resistance. The series resistance should be adjustable for calibration of the meter. The meter will only be capable of indicating average modulation, it can't move fast enough to show peak modulation.

Adjustment of the Exciter-Transmitter

Connect your power supply to the unit. Connect a 47 ohm, 1/2 watt resistor across the RF output connector. Connect a vacuum tube voltmeter (VTVM), Fet voltmeter, or oscilloscope across the 47 ohm load resistance. A good VTVM or Fet meter will measure frequencies up to 1000 kHz or so fairly accurately. To be sure however check the meter's specifications.

Switch on the power supply and observe the RF output voltage on the meter or the 'scope. Set the DC level control at minimum RF output and then at maximum RF output. Write down the measurements (voltage readings) of both extremes. Now adjust the DC level for an RF output level exactly 1/2 way between the two readings. This will give you the most output power consistent with 100% modulation that can be obtained. Adjust the tuning capacitor for maximum output. Remember the FCC Rules specify 100 milliwatts input power. This refers to the DC input power. The RF output power will be somewhat less. This unit puts out between 50 and 75 milliwatts. If you wish to know your exact output power you can do so with the following formula. $E^2/R = P$

Example: Voltage measured is exactly 2 volts (rms) on the meter. This is the same as 5.64 volts peak-to-peak on the 'scope. Load resistance is 47 ohms.

$$2^2/47 = 4/47 = .0851 \text{ watts} = 85 \text{ milliwatts}$$

Next, feed an audio signal at 0 dBm into the input. Set your modulation control at minimum. Set the peak loading control to maximum resistance (minimum loading). Watch the RF output voltage readings and adjust the modulation control. Adjust until some downward modulation is seen. This is seen on the meter by a drop in output voltage. On the scope you can see the modulation waveform and bright flashes appearing near its center. The flashes or bright spots are where the negative going modulation peaks are actually reducing the RF output to zero and then some. Stop at this point and adjust the peak loading control to eliminate the bright spots. The meter readings should return to normal.

Your transmitter is now adjusted for 100% modulation at 0 dBm audio input. If you use a VU meter on the transmitter, it can be set at 100%. Some adjustment of the DC level, modulation, and peak loading controls can produce up to 125% modulation on positive peaks. Negative peaks would remain at 100% modulation. This is allowed in AM broadcasting.

A 100 Milliwatt Repeater

This little amplifier was designed specifically for use with a 10 foot antenna in a direct radiation system. Its input power is 100 milliwatts (DC input) and can be driven to full output (50 to 75 milliwatts) with as little as 5 milliwatts of RF drive.

An additional feature of this amplifier is its ability to accept its DC power via the coaxial cable. In other words, a 12 volt supply is connected to the cable at the transmitter end - along with the output of the transmitter! The amplifier gets its DC power and its RF drive from the same coaxial cable.

Several of these amplifiers can be installed at intervals or at remote locations to provide controlled or "spot" coverage. Fig. 11A shows the schematic diagram.

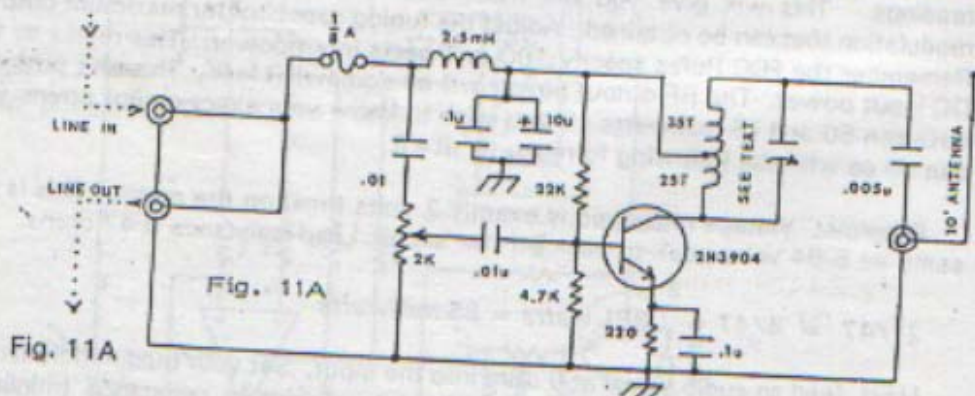

Circuit Description and Adjustment

The circuit is extremely simple in nature. The fuse should be a 1/16th ampere type (no larger than 1/8th amp.). The transistor is a 2N3904. The RF choke is a 100 microhenry unit (Radio Shack 273-102). The tuning of the output tank circuit is with a compression type trimmer, 170 - 900 picofarads. The tank coil is made from a 100 microhenry RF choke tapped at 25 turns (same as Exciter-Transmitter, 100 milliwatt unit) of Fig. 10). A second coax connector is in parallel with the input connector for easy continuation of a transmission line. The low current fuse assures an automatic disconnect from the system if the repeater malfunctions. The RF signal is isolated from the DC section of the unit by means of the RF choke. Likewise the DC is isolated from the input circuitry by a capacitor.

The D.C. voltages are blocked from the input power (RF) control by a D.C. blocking capacitor. Adjustment of this control is made to keep the input signal to the transistor from overdriving it, and to trim the output power to the desired level.

A 10 foot antenna should be connected directly to the output coaxial connector for best efficiency. The tuning capacitor is adjusted for best output signal. An oscilloscope probe held near the antenna should allow you to monitor the waveform during tuning. A portable radio is also handy for monitoring sound quality. Poor sound quality is a sure indication that the amplifier is being overdriven or the output tuning is improper.

The input impedance of the amplifier is between 1000 ohms and 2000 ohms depending on the setting on the input control. As such these amplifiers do not greatly disturb the low impedance of the coax line. This type of amplifier is said to be a "bridging amplifier". Several of these amplifiers can therefore be connected to a single coaxial line. 10 of these units connected to one coaxial line would present a net load of 40 ohms however when the line is terminated with a 50 ohm resistor. It is recommended that no more than 5 or 6 amplifiers be connected to a line. If more units are required for the system then a unit should be used as a "line booster".

The end of the coaxial line must always be terminated with a 50 ohm load. This can simply be two 100 ohm resistors connected in parallel and then connected between the center conductor of the line and shield. In this case you have a second connector on each amplifier. Simply install the 50 ohm load on the free connector of the last repeater on the line.

Fig. 11B shows how the D.C. power supply and the master transmitter are coupled together to the transmission line. A meter in series with the power supply gives an indication of how many repeaters are in operating order. If 5 repeaters are on line, for example, the meter should read about 50 milliamperes of current. If it reads only 40 milliamps then one of the repeaters has blown its fuse or is otherwise not operating. If the reading is higher then a transistor in one of the repeaters has shorted but does not draw enough current to blow the fuse.

The power supply used for this system is the same as that shown in Fig. 12.

Fig. 11C shows how this system can be used to provide "controlled" coverage to a number of isolated areas without exceeding FCC field strength limits.

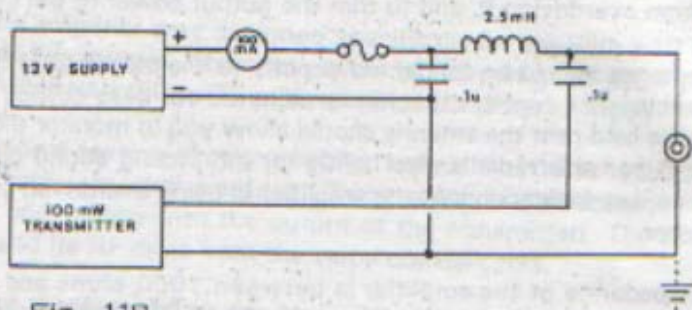

Fig. 11B

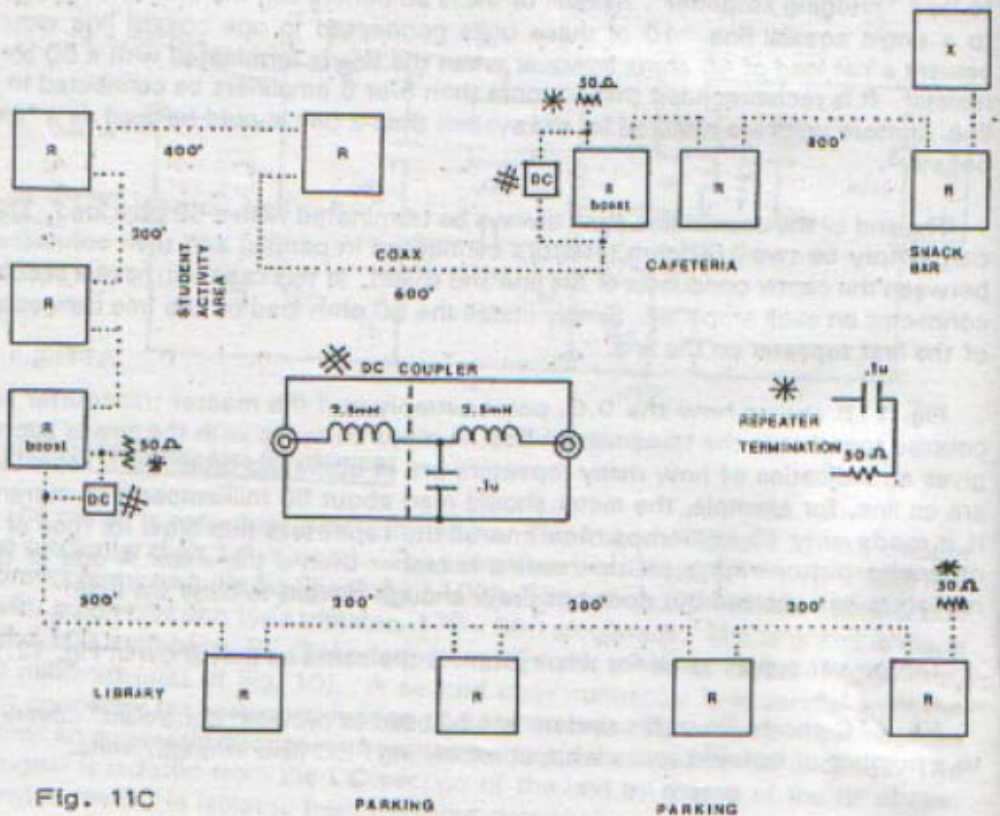

Fig. 11C

PARKING

PARKING

A 5 watt transmitter

For Carrier-Current operation, or for feeding induction cable, 50 to 75 milliwatts is not quite enough power. For example, it has been reported that a minimum signal is obtained in some college dorm's with about 1 watt per 100 residents. This would be 1 watt fed into the common electrical system. On a long run of induction cable it may be necessary to drive it with up to 2 watts. In difficult Carrier-Current installations, or where the radiating cable may be buried, more power would be required. A amplifier to fit all these needs would have to have a variable power output.

Fig. 10 shows the schematic of a 5 watt transmitter whose power is continuously adjustable from 0 to 5 watts. The "exciter" portion is to the left of the point marked with an "X". Its output is too low for direct use as a transmitter however. The transistors Q1 and Q2 are linear preamps which boost the signal to a level sufficient to drive the power amplifier section. The preamp circuit also "cleans up" the waveform from the exciter section. High order harmonics are removed before the signal reaches the power amplifier. This allows the use of broadcast transformers in the power amplifier.

The preamp and power amplifier sections can be constructed separate from the rest of the transmitter. When this is done you have a separate repeater capable of 5 watts output. The input to the repeater would be at point "X". The bridging input impedance is approximately 1000 ohms. If used on the end of coaxial cable, the cable should be terminated with the proper load. In the case of RG58 or RG8 for example, the load impedance should be 50 ohms. A full five watts output can be obtained with as little as 20 milliwatts. This repeater could also be used with the previously described exciter-transmitter (50 milliwatts output).

Circuit Description

The operating frequency is generated by a CD 4001 IC just like in the first described exciter. In this case the crystal is at the operating frequency. If greater frequency is desired the divider IC of the first exciter could be added here also. The frequency is adjusted by a 4-40 picofarad trimmer capacitor in the crystal circuit.

The output from the oscillator is fed into a 1496N chip. This chip was designed to generate double sideband signals as a balanced modulator. If the balance is upset however regular amplitude modulation results. The balance control is used in this case to add the desired amount of carrier to the modulated signal. Be sure to specify the 1496N or dual inline package, the other package has different pin connections.

Audio is fed to the 1496N modulator from a LM 741 op amp. No attempt has been made here to add negative peak loading or high frequency roll-off. Audio processing can be done external to the transmitter itself. An audio input control serves as the modulation control. An input resistor of 600 ohms (actually two 1200 ohm resistors in parallel) assures the proper audio input impedance. If a balanced audio line is to be used an input transformer will be required.

The output of the modulator is connected to the "output power" control. The output RF power of the transmitter is variable from 0 to 5 watts.

The filter between Q1 and Q2 removes any harmonics that may have been produced by the modulator chip. Since the modulator was fed with square waves from the oscillator-buffer, it was rich with harmonics. The filter is made from a 100 microhenry choke (Radio Shack 273-102) and two compression type trimmers. The trimmer capacitors are 170 to 600 picofarad range Calectro units (Cat. #A1-249). Larger range compression trimmers may be used but the 470 picofarad capacitors may have to be removed.

The output of Q2 is fed to the primary of a broadband (untuned) RF transformer. Its made from an Amidon FT-50B-61 ferrite core (1/2" diameter, 1/2" high, $\mu = 125$). Three # 20 varnished wires are wound at the same time (tri-filar winding) to make 5 turns. Two turns are removed from two of the windings to leave three turns each. These two windings are connected to make a transformer secondary winding with a center tap. The polarity of the windings must be observed for proper phasing. The primary is the 5-turn winding.

The center tap of the RF input transformer is connected to a bias diode. The diode has a voltage drop across it which is about equal to the voltage required to offset the "turn-on" potential of the power transistors. This allows the transistors to operate class B instead of class C. Class C operation would produce too much distortion (harmonics). The bias level must be kept somewhat constant for best operation. This is accomplished by the adjustment of the bias control. The circuit operates as a push-pull amplifier. As such it tends to cancel out even order harmonics that might otherwise be generated.

The power transistors are NPN, 12 volt, high frequency types used as the final RF amplifier in CB radios. Typical transistors are Motorola's HEP S3045 and RCA's SK3197 or other transistors with the same characteristics. Both transistors in the amplifier must be of the same type. Both transistors must also be heatsinked. Be sure to use insulating washers and heatsink compound when mounting.

The output transformer uses an Amidon FT-50B-61 core. Three # 20 varnished wires are wound through the core to make 6 turns each. The three wires are wound at the same time, side-by-side. Two of the windings are connected together to make a center tap. This makes a 12 turn primary winding. The secondary is 6 turns. When the unit is connected to a low impedance load, such as a power line, an appropriate coupler must be used.

Adjustment of the transmitter

Connect a suitable 5 watt dummy load to the output. Dummy loads, complete with an indicating light, can be picked up at CB stores. These are 50 ohms loads which also give a visual assistance in determining modulation.

Adjust the power control to minimum. Adjust the modulation control to minimum. Connect an audio signal to the input (2.2 volts peak-to-peak, or 0 dBm). Connect the power supply and switch it on. Move the modulator balance control all the way in one direction. Slowly increase RF output with the power output control. Stop when the dummy load lamp begins to glow. If you use a scope or meter to measure output stop when you have enough output to detect.

Adjust the two filter trimmer capacitors to obtain maximum RF output. Return the modulator balance control to its center position. Apply a small amount of modulation with the modulation control. Slowly adjust the balance control to insert carrier into the signal. This is best adjusted with an oscilloscope. Adjust to obtain an RF output waveform that looks like the one shown in appendix G. You will probably have to adjust both the modulator balance and the modulation controls to obtain a 100% modulated AM waveform.

Without modulation observe the output waveform with a 'scope. Readjust the filter trimmer capacitors and adjust the power transistor bias. You'll want to obtain a waveform like that shown in appendix G. All evidence of cross-over distortion, flat-topping, or other "wrinkles" in the wave form should be removed by these adjustments. Re-check for a 100% modulation waveform and readjust the modular balance if necessary. Your transmitter is now tuned and ready for operation.

The Power Supply

A power supply capable of handling any of the previously described transmitters or repeaters is shown in Fig. 12.

The AC input is equipped with a 1/4 to 1/2 ampere slo-blo fuse. The initial charging of the large filter capacitors causes a high current surge each time the supply is turned on. The slo-blo fuse won't blow immediately while a regular fuse would under the strain.

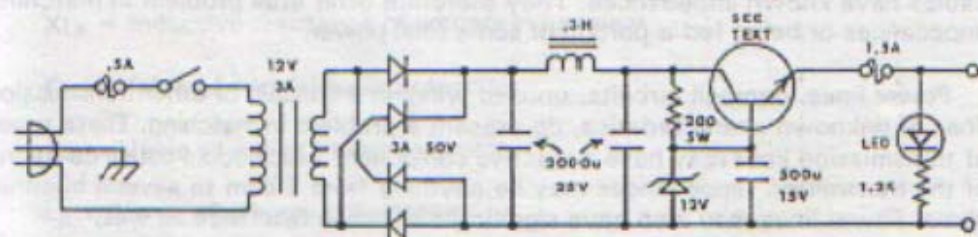

Fig. 12

The rectifier diodes must have at least a 2 ampere average current rating and a peak inverse voltage capability of 100 volts or better. Small diode bridges are available at nominal cost and make a neat looking construction job. The Transformer is a regular 12 volt type with a rating of 2 to 3 amperes. The power supply choke is a .3 Henry with a 2 amp rating. The choke could be eliminated without increasing ripple appreciably. The filter capacitors are 2000 microfarads each at 25 volts. If the choke is removed from the circuit use one 4000 microfarad capacitor instead of the two capacitors.

A capacity multiplier type circuit is used to further smooth out the DC. Any NPN power transistor which can handle 2 amperes and has a dissipation of 10 watts can be used. The Zener diode is rated at 400 milliwatts and 12 volts. The base capacitor is 500 microfarads at 15 volts. The output of the supply is fused for 1.5 amperes.

The milliwatt Exciter-Transmitter and the 100 milliwatt repeater do not require a power supply as hefty as this one. They could be operated from "wall adapter" type supply capable of 12 to 15 volts at 40 milliamperes.

RF COUPLING AND POWER SPLITTING

Transmission of your signal by power line, induction cable, antenna, or simply feeding power into a coaxial cable for a distant location, all have two things in common. These are impedance matching and power splitting.

Both impedance matching and power splitting are relatively easy when dealing with known impedances and power levels. Induction cables and regular coaxial cables have known impedances. They therefore offer little problem in matching impedances or being fed a portion of some total power.

Power lines, doorbell circuits, unused wires in a conduit, or other transmission lines of unknown characteristics, do present a problem in matching. These types of transmission lines may have a reactive component which could cause de-tuning of the transmitter. Impedances may be anything from 1 ohm to several hundred ohms. Power lines may also have significant inductive reactance as well.

An RF coupling device can be designed to introduce an opposite and equal reactance (capacitive) and at the same time match a 50 ohm transmitter to a very low impedance line. Toroidal cores are usually used for the construction of the RF coupling transformer. They offer a high power efficiency, a low external field loss, are small in size, and are inexpensive. When wound with wire in a certain way the effects of leakage inductance, distributed capacitance, coefficient of coupling, and other transformer characteristics can be minimized.

It is most advantageous to keep a toroid winding limited to a single layer. When multiple layers are used the inner layers tend to shield the outer ones with a resultant loss in coupling between the two. For this reason also, the primary and secondary windings are usually wound "bi-filar". A bi-filar winding is where both the windings have their wires side by side and are wound at the same time.

Power splitting makes use of transformer action to take some input power and divide it down into several lower power levels for feeding branches in a system. The power handling capability of small toroid cores is quite good. For power levels under 10 watts a 1/2" diameter core is sufficient. Twice the power level requires a core at least 4 times as large or 2" diameter.

The following pages give several examples of RF coupler and power splitter designs.

RF Coupler Design

Criteria: Match 3 ohm power line impedance to a 50 ohm transmitter. Primary inductive reactance should have a negligible affect. There should be means for tuning-out any load inductive reactance.

Abbreviations used in the following calculations:

X_{cp} = Capacitive reactance of parallel tuning capacitor

X_{Lp} = Inductive reactance of primary inductance

C_p = Value of parallel tuning capacitor

C_s = Value of series tuning capacitor

L_p = Value of primary inductance

N_p = Number of turns in primary winding

N_s = Number of turns in secondary winding

Z_1 = Impedance at input of coupler

Z_2 = Impedance at output of coupler

P_1 = Input power to coupler

P_2 = Output power from coupler

f = Operating frequency

* A_L = Is used in calculations when using AMIDON toroid cores

* The toroidal core selected for this design example is AMIDON's FT-50B-61. The core is .5 inch high, has a .5 inch outside diameter, and a .312 inch in side diameter. It has a "mu" (permeability) of 125. The term "AL" is given in AMIDON's design book. It can handle approximately 15 watts without saturating.

Design Example

For the purpose of this example we will assume the following:

- (1) Input power is 5 watts
- (2) Inductive reactance of the primary winding will be 10 times the input impedance of 50 ohms (500 ohms)
- (3) Operating frequency = 700 kHz

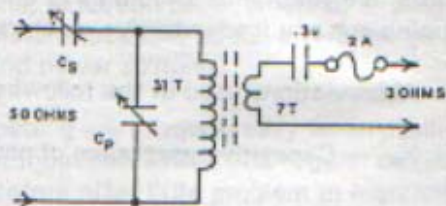

$$\text{Solve for primary inductance: } L_p = \frac{X_{L_p}}{6.28 f} = \frac{500}{(6.28)(700,000)} = .114 \text{ mH}$$

$$\text{Solve for tuning capacitor: } C_p = \frac{.159}{(X_{C_{opt}})} = \frac{.159}{(500)(700,000)} = 400 \text{ pF}$$

$$\text{Solve for primary turns: } N_p = 1000 \sqrt{\frac{L_{p_{mH}}}{A_L}} = 1000 \sqrt{\frac{.144}{150}} = 31 \text{ turns}$$

Now comes the number of turns for the secondary N_s :

$$N_s = N_p \sqrt{\frac{Z_2 P_2}{Z_1 P_1}} = 31 \sqrt{\frac{(3)(5)}{(50)(5)}} = (31)(.2449) = 7 \text{ turns}$$

Since the power line's inductive reactance is difficult to measure without expensive equipment the calculation of C_s is also difficult. In most applications it must be found by trial and error. A compression type trimmer capacitor with a range of 170 picofarads to 900 picofarads gives ample tuning for C_p . A larger trimmer, 1400 to 2800 picofarads, is required for C_s to adequately tune-out power line reactance. (ARCO # 469 is good for C_p) (ARCO # 313 is good for C_s).

The FT-50B-61 core will hold 31 turns of # 26 varnished wire for the primary winding and 7 turns of # 20 varnished wire for the secondary. Larger wire is used for the secondary due to the larger current requirement.

Adjustment of the coupler

The output of the coupler is left unterminated and a small signal is fed into its input. If a transmitter is used to supply the input signal then precautions should be taken to assure the transmitter is terminated properly. This can be done with a "pad". It reduces the available power to the coupler, provides a 50 ohm termination for the transmitter, and provides a 50 ohm source for the coupler.

Measure the voltage (AC) across the coupler primary. Adjust C_p for the highest voltage obtainable. The primary inductance is now tuned-out of the circuit.

Now apply the load by connecting the coupler output to the power line with suitable isolation and fusing. Measure the RF voltage across the secondary winding of the coupler. Adjust C_s for a maximum reading. C_s and C_p interact with each other. Several adjustments of each will be required before a purely resistive 50 ohms is presented to the transmitter.

A common mistake is coupling to the power line through too small of a coupling capacitor. To avoid any capacitive reactance component from being included in your power line impedance, the reactance should be less than 20% of the expected line impedance. For an expected line impedance of 3 ohms (our example) the capacitive reactance of the capacitor should not exceed .6 ohms at your operating frequency (700,000 Hz in our example). Voltage rating should be 600 VAC.

$$C_c = \frac{.159}{(X_{cc})f} = \frac{.159}{(.6)(700,000)} = .378 \mu F \quad (.3 \mu F - .5 \mu F \text{ is close enough})$$

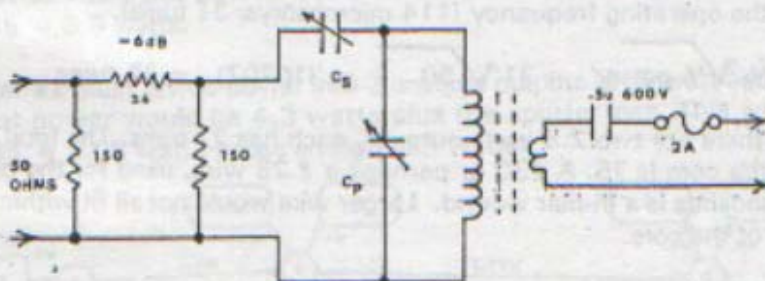

Power Splitters

Power splitters are used when two or more loads are to be furnished power from one source. The loads may receive equal amounts of power or fixed percentages of the available power. The total power from all secondary taps is always slightly less than the input power to the splitter.

Power splitters can be constructed from the same toroidal cores that are used for RF couplers. The secondary windings however should be wound bi-filar, tri-filar, or whatever, for adequate coupling. The term bi-filar simply means two wires run side-by-side. In a two secondary splitter the two windings are wound at the same time with one wire from each winding next to each other. The wires may be twisted together first before actually winding on the core to assure they are bi-filar.

The following formula finds the number of secondary turns relative to the primary turns and are similar to that for couplers. The exception is that the "Z" (impedance) term can be dropped-out if the input and output impedances are equal. This is so when a 50 ohm transmitter is feeding a splitter that in turn feeds 2 or more 50 ohm coaxial lines. #1 is the original, #2 with Z dropped out, #3 is the final version.

$$N_s = N_p \sqrt{P_2 Z_2 / P_1 Z_1} \quad N_s = N_p \sqrt{P_2 / P_1} \quad \text{or simply} \quad N_s = \sqrt{\% \text{ power}}$$

Design Example:

A power splitter must provide 2.5 watts into each of two 50 ohm induction cables. Input to the splitter is from a 5 watt, 50 ohm transmitter. The splitter core is an AMIDON FT-50B-61. The primary winding has an inductive reactance of 500 ohms at the operating frequency (114 microhenrys, 31 turns).

$$N_s = N_p \sqrt{\% \text{ power}} = 31 \sqrt{.50} = 31(.707) = 22 \text{ turns}$$

Since there are two 2.5 watt outputs, each has 22 turns. The total number of turns on the core is 75. A #30 or perhaps a #28 wire, used for the primary and both secondaries is a tri-filar wound. Larger wire would not all fit within the inside diameter of the core.

The inductive reactance of the primary, and that of the loads, is tuned-out by a series capacitor Cs. An ARCO #313 compression trimmer (1400-2800 picofarads) is suitable for this purpose.

Fig. 15 shows the result of our power splitter design. In this particular case the secondary windings are isolated from each other. An autotransformer design is also possible which provides "taps" for the selection of the desired power. These will be discussed later in this chapter.

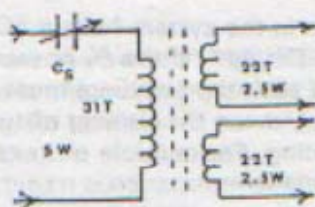

Fig. 15

Another consideration is that RF couplers and power splitters are not 100% efficient. An insertion loss of up to 1 dB can be attributed to each coupler or splitter used. A typical loss is in the order of .6 dB however. A .6 dB loss represents an efficiency of about 85%. This amount of loss is sometimes not worth worrying about. As it turns out the signal voltage only drops to 92% when the power is dropped to 85% (% voltage is equal to the square root of the % power). Never the less, you may want to include these losses in your system design.

Fig. 16 represents 6 buildings that are fed with induction cable. The buildings are in groups and require a run of regular coaxial cable to get power to them. It has been determined that buildings D, E and F each require .5 watt of power. Building B requires .5 watt while building C needs 1 watt. Building A also requires .5 watt of power. Three power splitters are needed.

Splitter #3 must divide power into 3 equal outputs (.5 watt each) Its input power must be (3) (.5) plus the splitter loss. $1.5 \text{ watts} / .85 = 1.75 \text{ watts}$.

Splitter #2 must divide power into 3 unequal outputs of .5 watt, 1 watt, and 1.75 watts. The input power would be 3.25 watts plus the splitter loss. $3.25 \text{ watts} / .85 = 3.8 \text{ watts}$.

Splitter #1 must divide power into 2 unequal outputs of .5 watt and 3.8 watts. The input power would be 4.3 watts plus the splitter loss. This would be $4.3 \text{ watts} / .85 = 5.05 \text{ watts}$ (close enough to 5 watts)

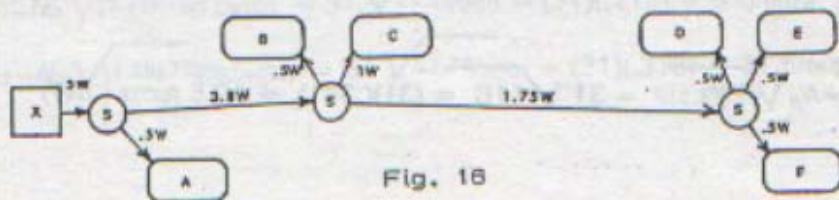

Fig. 16

All cables in the system have a 50 ohm impedance so our calculations are quite simple. We simply find the % power, compared to the total output power of the splitter, that each tap (winding) must provide. The square root of that % expressed as a decimal, times the number of turns in the primary tells us the number of turns for the winding. For multiple outputs use the second formula.

$$N_s = N_p \sqrt{\% \text{ power as a decimal number}} \quad \text{or} \quad N_s = N_p \sqrt{\text{power required} / \text{total output}}$$

Applying formula 2, a 31 turn primary, .5 W output, total output of 1.5 W:

Splitter #3:

$$N_s = N_p \sqrt{.5 \text{ watt} / 1.5 \text{ watt}} = 31$$

Splitter #2:

$$N_s = N_p \sqrt{.5 \text{ W} / 3.25 \text{ W}} = 31 \sqrt{.154} = (31)(.392) = 12 \text{ turns (.5W)}$$

$$N_s = N_p \sqrt{1.75 \text{ W} / 3.25 \text{ W}} = 31 \sqrt{.538} = (31)(.734) = 22.7 \text{ turns (1.75W)}$$

$$N_s = N_p \sqrt{1 \text{ W} / 3.25 \text{ W}} = 31 \sqrt{.308} = (31)(.554) = 17 \text{ turns (1W)}$$

Splitter #1:

$$N_s = N_p \sqrt{3.8 \text{ W} / 4.3 \text{ W}} = 31 \sqrt{.884} = (31)(.940) = 29 \text{ turns (3.8W)}$$

$$N_s = N_p \sqrt{.5 \text{ W} / 4.3 \text{ W}} = 31 \sqrt{.116} = (31)(.341) = 10.5 \text{ turns (.5W)}$$

The Autotransformer

The calculations for an autotransformer are the same as the isolated winding splitter just discussed. The main difference is the autotransformer has only one winding. Taps are located along the winding for selection of power levels.

The following relationships exist for a 31-turn autotransformer shown below:

% power	% turns	# of turns
70	83.6	25.9
50	70.7	21.9
25	50.0	15.6
10	31.0	9.8
05	22.4	6.9
01	10.0	3.1

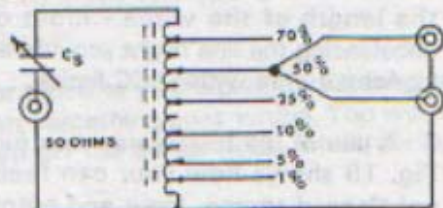

The above calculations are of course based on a 50 ohm input and output impedance. If two 50 ohm outputs at 50% power are required they are both taken from the same tap. In other words two cables, each 50 ohms, would be fed 50% of the power when they are both connected to the same 50% tap.

An expanded example would be: One cable connected to the 50% tap, one cable connected to the 25% tap, two cables connected to the 10% tap, and 5 cables connected to the 1% tap is a total of 100%

Different Impedances and Powers

Fig 18 shows a power splitter which also must match different impedances. The formula must now include the impedance of the secondary and the primary:

$$N_s = N_p \sqrt{P_s Z_s / P_p Z_p}$$

$$N_{s1} = N_p \sqrt{(3.75)(3)(5.0)(50)} = 31 \sqrt{11.25/250} = (31)(.212) = 6.6 \text{ turns}$$

$$N_{s2} = N_p \sqrt{(1.25)(75)(5.0)(50)} = 31 \sqrt{93.75/200} = (31)(.375) = 11.6 \text{ turns}$$

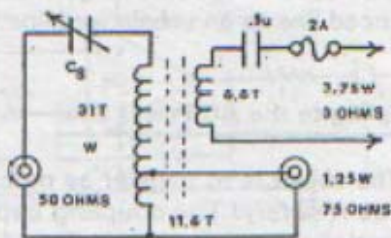

Unbalanced to Balanced Conversions

Where you propose to transmit your signal on a pair of wires, twisted or otherwise, and wish to keep a limit on radiation, you will need a method of "balancing" the system. A balanced system has equal amounts of energy flowing in both wires but in opposite directions. The net effect is very little radiation along the length of the wires - most of the power gets to the other end. Slightly unbalancing the line might provide a means for controlling radiation for a receivable signal yet stay within FCC limits.

A pair of old telephone wires (unused) might exhibit an impedance of 91 ohms. Fig. 19 shows how you can feed the 91 Ohm balanced line from a 50 Ohm unbalanced source. Input and output power are assumed to be the same.

$$N_s = N_p \sqrt{Z_{out}/Z_{in}} = 31 \sqrt{91/50} = 31 \sqrt{1.82} = (31)(1.35) = 42 \text{ turns}$$

The 42 turn secondary is balanced by grounding a mid-point tap at 21 turns. The primary consists of 21 + 10 turns. A total of 52 turns is required for this example. The transformer can also be used in reverse to go from a balanced line to an unbalanced line.

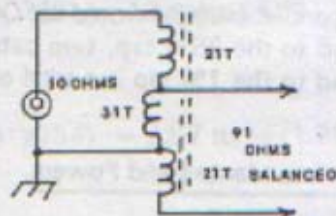

Coupling to the AC Power Line

The object is to transfer as much RF power to the AC power line as possible, *but do it safely!* The coupling capacitor's value is carefully chosen to provide essentially a one-way transfer of energy. It's reactance must be low at radio frequencies but high at the power line (60 Hz) frequency. In case of capacitor failure a fuse is required. A 2 ampere rating should handle up to 12 watts into 3 Ohms.

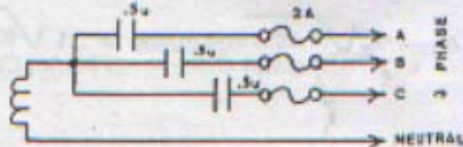
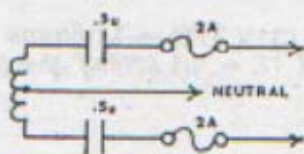

OFF - AIR MONITORING

There is no better way to assure good air sound quality than to listen to your own signal. It is a mistake to listen to the output of your audio console for example, it always sounds good. What if your transmitter has failed? What if an audio line is broken? How would you know what happened if you're listening to the console only? You wouldn't!

An off-air monitor is simply a radio receiver tuned to your signal. By listening to it you'll know as soon as everyone else when something goes wrong. You would be surprised at how many stations have been off the air for hours while the DJ merrily plays music to himself.

A very simple receiver for monitoring is shown in Fig. 21. Its antenna lead is simply brought close to your outgoing transmission line. If you are putting out only a few milliwatts it may be necessary to wrap the antenna lead around your cable or have it close to the antenna. The circuit is a diode detector whose output is coupled to a LM 741 op amp. The output from the LM 741 can drive a pair of earphones directly. If more volume is desired it can be coupled to a power amplifier and loud speaker. It requires only a few milliamps of DC current at 9 to 12 volts. It could get its power from the transmitter power supply, a 9 volt battery, or a 9-12 volt wall adapter DC supply.

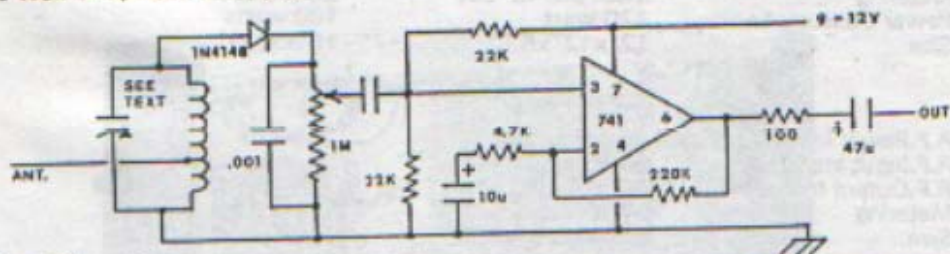

Fig. 21

The coil is a Radio Shack 100 microhenry choke tapped at 25 turns from the ground end. The circuit is tuned with a 170 to 900 picofarad compression type trimmer. A 1 Meg potentiometer is used as a volume control. All resistors are 1/2 watt types.

Also consider that the output can be used to drive an oscilloscope or VU meter. The 'scope can be used to monitor waveform and modulation. The VU meter can be used to show percentage of modulation.

COMMERCIAL EQUIPMENT

The following table shows typical specifications for the two major manufacturers of Carrier-Current equipment. It is not the author's intent to recommend one over the other, but simply to provide you with the information contained in their sales literature.

SPECIFICATIONS	LPB, Inc.	Radio Systems, Inc.
	<u>(TRANSMITTER)</u>	
R.F. Power Output	Adj. - 20 watts	Adj. - 20 watts
Frequency Range	530 - 1610 kHz	500 - 1700 kHz
Output Impedance	50 ohms	50 ohms
Harmonic Suppression	40 dB	45 dB
Frequency Stability	.003%	.002%
Carrier Shift	Less than 2%	2% maximum
Harmonic Attenuation	45 dB or better	45 dB or better
A.F. Input Impedance	600 ohms (bal.)	600 ohms (bal.)
Frequency Response	20Hz-15kHz(1.5dB)	20Hz-15kHz(1.0dB)
Distortion at 99% mod.	Less than 3%	Less than 2%
Minimum level input	-15 dBm	-30 dBm
Noise	-55 dB	-60 dB
Metering	Mod. and RF out	Mod. and RF out
Power Consumption	120 watt	100 watts
Size	12"x12"x6.5"	15"x9"x6"
	<u>(POWER LINE COUPLER)</u>	
R.F. Power Input(maximum)	25 watts	20 watts
R.F. Input Impedance	50 ohms(unbal.)	50 ohms(unbal.)
R.F. Output Impedance	1,2,5,10,50 ohms	1-50 ohms, 15 ranges
Metering	SWR bridge	SWR bridge
Size	8.5"x10.5"x2.75"	9"x9"x3" Weight

In addition to the above, both companies also offer consulting services. Both companies are also prepared to handle complete installations including studio equipment and support materials. The address and phone number of each is included in appendix C.

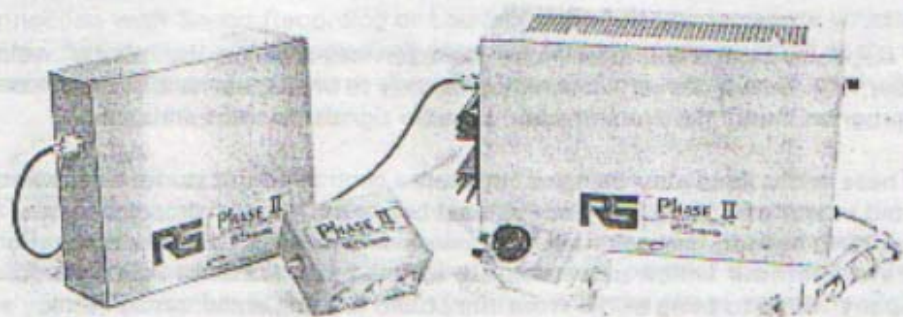

ABOVE: Power Line Coupler (left), 20 watt transmitter (right). Photographs courtesy of Radio Systems Inc.

BELOW: 60 watt transmitter. Photograph courtesy of LPB, Inc.

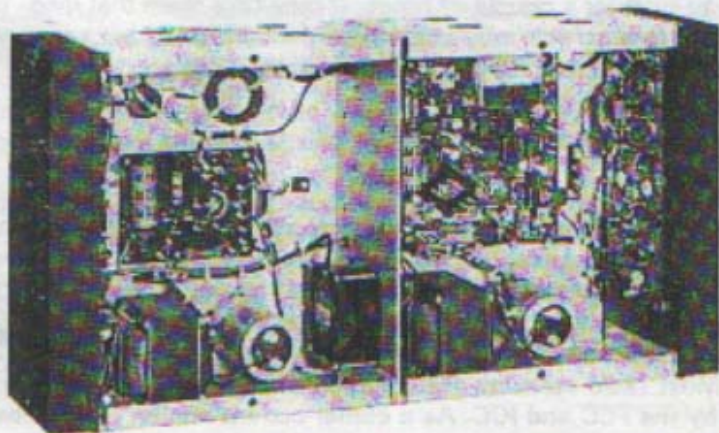

TELEPHONE FACILITIES

Telephone companies offer many more services than just the "phone" we're all familiar with. One of the services relates directly to broadcasters. It's the installation of "program lines" for transmission of audio signals for radio stations.

These audio lines may be used between a central control studio and a remotely located transmitter. They can also be used between "remote" broadcast sites, such as sporting events, council meetings, news sources, etc., and the studio. Carrier-Current systems which use remotely located transmitters often use "phone company" lines to bring audio from the studio to each of the transmitters.

The biggest problem in establishing a program line for your station is finding someone in the telephone company that knows what you need. The business office knows nothing except regular telephone services.

Check with a local radio station (engineering section) and ask if they have the phone number to call. If you can't get it that way you'll have to go the long way around. Call the business office and ask for a supervisor. Explain that there is a special section of the company that works with radio station lines called "radio loops", "Program lines", and sometimes "long lines". Ask for the number to call. Be prepared to wait for a couple of hours, it may take them that long. The first few people you talk to after that may still not be the right ones, but keep trying. Sooner or later you'll reach someone that knows exactly what you want.

Line Costs

Of course the telephone company has to charge a monthly fee for every line they install. The fee is based on the frequency response of the line and whether it is used by a licensed station or an unlicensed station. As a carrier-current station, or low power AM station, you would be considered as an unlicensed station. As such, the fee should be LESS. The telephone company may have to be reminded about this. Most radio stations are commercial and are subject to interstate tariffs as set forth by the FCC and ICC. As a carrier-current station you can be considered as intra-state commerce and thereby qualify for a lower fee.

The people at the telephone company probably won't know much about Carrier-Current stations. They just don't deal with them that often. You should point

out the differences during your initial contact with the "radio loop" engineer. Explain that the tariff should be for "Private Channels for Music Transmission in Connection with Sound Recording or Loudspeakers". If you introduce yourself as a radio station they will automatically assume you should be charged at the same rate as other radio stations. Explain yourself fully and save money!

Types of line

Lines are classified according to their frequency response characteristics. Code numbers for these lines may be different in different parts of the country. Just be sure you designate the proper line when you talk with the phone company engineer. The grades of lines are as follows:

200 Hz to 3,500 Hz	This is the lowest grade of line. Frequency response is not really suited to broadcasting.
100 Hz to 5,000 Hz	Fine for Carrier-Current broadcasting. Often used by commercial AM stations.
50 Hz to 8,000 Hz	More frequency response than you'll need. Remember AM stations are limited in bandwidth to about 5,000 Hz. Most AM receivers are not designed to respond to anything over 6,000 Hz anyway. Waste of money to get these lines.
50 Hz to 15,000 Hz	Excellent frequency response. Used by FM stations. Not worth the added expense when used for Carrier-Current or low power AM broadcasting.

For carrier-current purposes then, only the 5,000 Hz line should be considered. The next question is if the line should be "equalized" or left "unequalized".

An equalized line is one which has been checked by the telephone line installer and has been frequency compensated. Chokes, capacitors, and transformers are added to the line to assure equal response to all frequencies within the line's specifications. The response is then guaranteed by the telephone company to be within 1 dB over the specified range. Of course, there is a charge for the equalizing service plus an increase in the monthly fee.

An unequalized line may not have a perfectly flat frequency response but still be quite acceptable. This is especially true when the line is less than a couple of thousand feet in length. Such a case would be a line on a school campus, an apartment complex, church facilities, etc. The line would simply be one of many other pairs in a master cable running from one phone terminal box to another. Longer cables, like those between several city blocks, usually have too much shunt capacity to be used without some form of equalization.

The telephone company, of course, has access to all points of these longer lines and can add compensating devices to equalize your line. You do not have that access however, but you may still be able to get by with a long unequalized line. You would simply order the unequalized line and test it yourself. You can then attempt to equalize it yourself. If you fail to get the desired results all you have lost is a little time. You can always call the telephone company and have them equalize the line later.

One way of equalizing is to lower the source and load impedance connected to the line. This lowers the effect of the line's shunt capacity and thereby raises the high frequency response. Usually the impedances are lowered from the standard 600 ohms to 150 ohms by a suitable transformer.

A second approach is to add a passive equalizing circuit at the load end of the line. The loading effect of the equalizer tends to attenuate the mid-range frequencies. Adjustment is quite easy: First, connect a 6 dB pad between the audio source and the line input. Next, feed a 8,000 Hz signal into the line and measure the audio level at the load end. Now, feed a 1,000 Hz signal down the line (at the same amplitude as the 8,000 Hz). Lastly, adjust the control until the 1,000 Hz level is the same as the 8,000 Hz level. You may have to repeat the process a few times to get it correct.

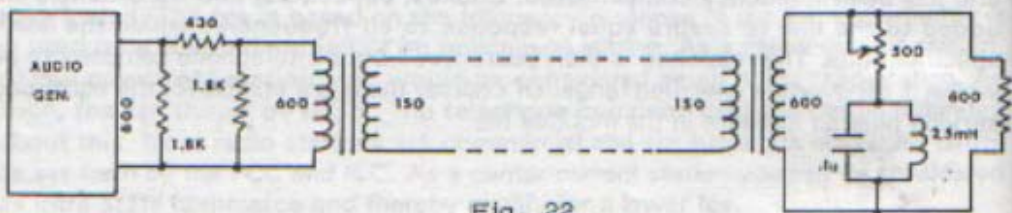

Fig. 22

Fig. 22 shows the complete test and equalizing set up.

An added advantage of the less expensive unequalized line is it is often available as a "D.C. pair". This simply means the line has electrical (D.C.) continuity - no isolating transformers on the line. This is quite handy for remote control and monitoring of a distant transmitter. Fig. 23 shows three methods of transmitter control with the same lines used to feed audio to the transmitter.

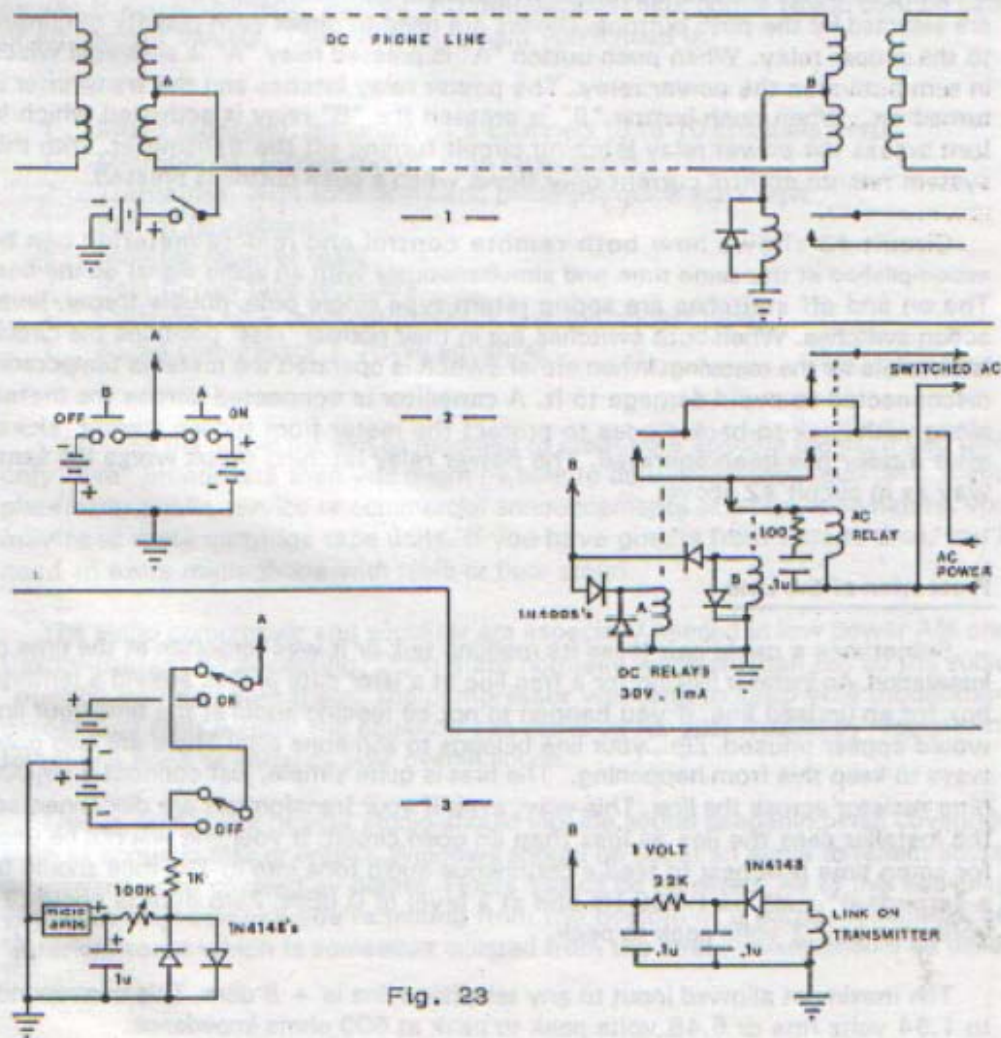

Fig. 23

Circuit #1 is the simplest control circuit. Closure of the switch at the studio causes current to flow equally through both wires of the telephone line, through the the relay, and then return through the conductive path of the Earth. The relay controls the AC power to the transmitter. Opening the switch shuts the transmitter off. The equal currents in the two wires pass through the transformer windings in opposite directions which has no effect on the transmission of audio.

Circuit #2 has a more elaborate switching circuit. Different polarities of current are selected by the push buttons. Diodes are used to direct each polarity of current to the proper relay. When push-button "A" is pressed relay "A" is activated which in turn activates the power relay. The power relay latches and the transmitter is turned on. When push button "B" is pressed the "B" relay is activated which in turn breaks the power relay latching circuit turning off the transmitter. With this system remote control current only flows when a push button is pressed.

Circuit #3 shows how both remote control and remote metering can be accomplished at the same time and simultaneously with an audio signal on the line. The on and off switches are spring return type single pole, double throw, lever action switches. When both switches are in their normal "rest" positions the circuit is complete for the metering. When either switch is operated the meter is temporarily disconnected to avoid damage to it. A capacitor is connected across the meter, along with back-to-back diodes to protect the meter from sudden current "kicks" after a relay has been operated. The power relay latching circuit works the same way as in circuit #2 above.

Protection of the Line

Sometimes a cable pair loses its marking tag, or it was forgotten at the time of installation. An installer looking for a free line at a later date probes around a terminal box for an unused line. If you happen to not be feeding audio at the time your line would appear unused. Zip...your line belongs to someone else! There are two good ways to keep this from happening. The first is quite simple, just connect a 10,000 ohm resistor across the line. This way, even if your transformers are disconnected, the installer sees the line as less than an open circuit. If your line will not be used for some time it is best to feed a continuous audio tone into it. The tone should be a "standard" such as 1,000 Hz and at a level of 0 dBm. Zero dBm is about .77 volts rms or 2.2 volts peak to peak.

The maximum allowed input to any telephone line is + 8 dBm. This corresponds to 1.94 volts rms or 5.48 volts peak to peak at 600 ohms impedance.

STUDIO FACILITIES

No matter how good your transmission equipment is, your station still depends on the sound quality of the studio. It is not always necessary to buy expensive equipment, however, to assure that quality. There are many good used broadcast equipment dealers, inexpensive equipment manufacturers, and consumer type hi-fi equipment. Appendix C (Sources) lists some manufacturers and dealers which handle studio equipment. Appendix D (References) lists books which contain lists of equipment dealers. The basic equipment you'll need is:

- 1 Mixer (console), minimum of 5 channels (8 to 10 channels best)
- 1 Microphone, unidirectional, with table stand
- 2 Turntables, with tone arms and preamps, quick start type
- 1 Pair of headphones
- 1 Monitor receiver (AM)
- 2 Reel-to-reel tape recorders
- 1 Cartridge tape recorder/playback unit (broadcast type)
- 1 Audio compressor 1 Audio equalizer

Of course the above list can be modified to meet your specific needs. If you plan only "live" broadcasts then you might be able to do without tape recorders. If you plan many public service or commercial announcements of a repeating nature, you may need more cartridge tape units. If you have guests from time to time, you'll need an extra microphone with table or floor stand.

The audio compressor and equalizer are especially needed in low power AM and Carrier-Current broadcasting. Signals are normally weak and can use all the audio "punch" you can give them. The compressor will tend to keep your modulation percentage high (loud!); the equalizer can make up for poor frequency response of telephone lines or enhance your overall sound.

The physical layout of your studio should include sound deadening wall coverings such as acoustic tiles or drapes. Windows should be set at an angle to reflect sound downward or be covered by drapes. Floors should be carpeted. All of this will keep you from sounding like you're talking from the bottom of a barrel. In addition, an "interior" room which is somewhat isolated from the street noises should be used.

APPENDIX ACommon Coaxial Cable Characteristics

TYPE	*Z (ohms)	OD (in.)	dB LOSS per 100 ft.		Manufacturers
			(500 kHz)	(1000 kHz)	
RG-8	50	.408	.123	.174	Alpha 9008 Beldin 8214
RG-58	53.5	.195	.313	.443	Alpha 9058 Beldin 8240
RG-174	50	.100	.600	.780	
RG-217	50	.545	.113	.160	
RG-11	75	.412	.146	.207	Alpha 9011 Beldin 8238
RG-59	75	.242	.246	.348	Alpha 9059 Beldin 8212
RG-62	93	.242	.186	.263	Alpha 9062 Beldin 8254
RG-17A	52	.870	.051	.073	

*Z = Characteristic Impedance of cable

APPENDIX B

Balanced Transmission line Characteristics

TYPE	*Z (ohms)	dB LOSS (per 100 ft.)	
		[500 kHz]	[1000 kHz]
TV Twinlead	300	.09	.12
TV Twinlead (Shielded)	300	.27	.38
TV Twinlead-75	75	.07	.10

Twisted or Paired Wires used as Transmission Lines

ZIP CORD	(18-2) 85	.28	.43
SPEAKER WIRE	(#20) 75	.38	.57
TELEPHONE WIRE (1 pair #24 wires)	60	.44	.65
TELEPHONE WIRE (C Rural Wire)	118	.15	.21
TELEPHONE WIRE (C Drop Wire)	92	1.2	1.5
MILITARY WIRE (Surplus WC-534 Field)	93	.31	.53
TWISTED DOOR BELL	39	.29	.44

*Z = Characteristic impedance of line when in dry open air. Impedance and loss will change when line is run in conduit or is buried.

APPENDIX CSourcesCarrier-Current Equipment

LBP, Inc (catalog)
28 Bacton Hill Rd.
Frazer, PA 19355
(215) 644-1123

Radio Systems (catalog)
5113 West Chester Pike
Edgemont, PA 19028
(215) 356-4700

Surplus Radio Dealers

Fair Radio Sales Co. (catalog)
PO Box 1105
1016 E. Eureka St.
Lima, OH 45802
(419) 227-6573

Electronics Salvage
2706 Middle Country Rd
Centereach, NY 11720
(800) 645-5030 (catalog)

Amidon Associates (catalog)
2216 E Gladwick St PO Box 956
Dominguez Hills, CA 90220
(213) 753-5770 (ferrite cores)

Cable Suppliers

Burden Associates
20944 Sherman Way
Canoga Park, CA 91303
(213) 340-4590 (induction cable)

Sierra Western Cable
P.O. Box 23872
Oakland, CA 94623
(415) 832-3527 (wholesale cable)

Parts Suppliers

Mouser Electronics
PO Box 699
Mansfield, TX 76063
(800) 992-9943

McGee's
1901 McGee St
Kansas City, MO 64106
(816) 842-5092 (catalog)

Radio Shack
Most major cities

All the above companies will send a catalog upon request.

APPENDIX D

References

The Radio Amateur's Handbook
ARRL Staff
1945 and 1990 Editions

FCC Information Bulletins
OST 63 (1984) Supersedes OCE 11

AM-FM Broadcasting
by Ennes Howard
Sams Publishers

Carrier-Current System Design
by Sibley & Bloom
IBS

"Tech Notes"
LPB, Inc.

Radio Station Development
Cable FM Broadcasting
Equipment Sources
Reference Book of Reference Books
by Wilson
Panaxis Productions

Broadband Transformers
Application Note 749
by Granberg
Motorola Semiconductors

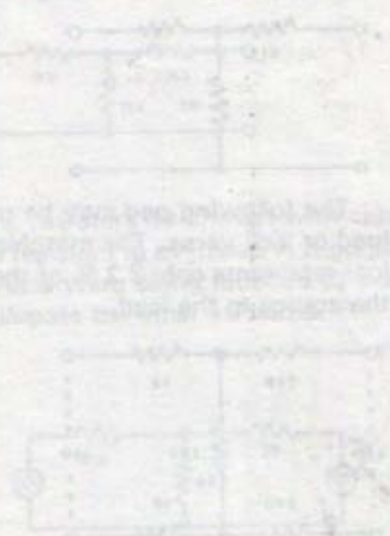

APPENDIX E

Fixed Attenuator Pads

Signal levels may be conveniently reduced with any one of the following attenuator pads. Resistance values have been calculated to the nearest EIA standard. "T" and "Pi" type pads are used for unbalanced circuits. The "H" pad is used for balanced circuits. Simply select the desired pad type and the desired attenuation - then construct the pad with the applicable resistance values.

600 ohm/600 ohm

[dB] LOSS	% Transfer		"T"			"Pi"	
	Pwr	Volts	R1	R2	R3	R4	R5
1	79	89	36	5.1k	18	10k	68
2	63	80	68	2.7k	36	5.1k	150
3	50	71	100	1.8k	51	3.6k	220
4	40	63	130	1.2k	68	2.7k	270
5	32	57	160	1k	82	2.2k	360
6	25	50	200	820	100	1.8k	430
7	20	45	220	680	110	1.5k	560
8	16	40	270	560	130	1.3k	680
9	12.6	35	300	470	150	1.3k	750
10	10	32	300	430	160	1.2k	820
20	01	10	510	120	240	750	3k

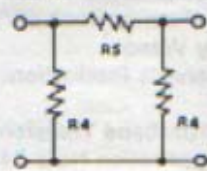
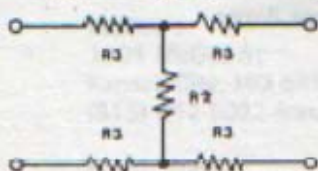

The following pad may be used for matching a 600 ohm source to a 150 ohm load or vice versa. The matching pad has an inherent loss of 15 dB however. This loss represents only 3.2 % of the power (17.8% of the voltage) as transferred from the source to the load.

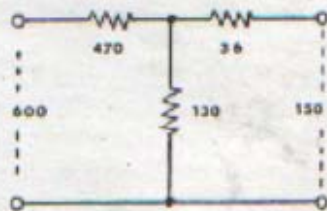
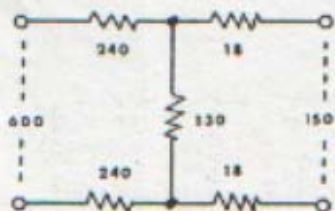

APPENDIX F

Fixed 50 & 72 Ohm Attenuator Pads

Sometimes it is necessary to reduce power being fed to a 50 or 72 ohm load or transmission line. Both the "T" and "Pi" type pads work nicely for this application. Resistance values have been calculated to the nearest EIA standard. Simply select the desired pad type and the desired attenuation - then construct the pad with the applicable resistance values shown below.

dB	% Transfer Pwr	Volts	R1		*Pi* R2		R3		*T* R4	
			(50)	(72)	(50)	(72)	(50)	(72)	(50)	(72)
1	79	89	820	1.2k	5.6	8.2	3	4.3	430	620
2	63	80	470	620	12	16	5.6	8.2	220	330
3	50	71	300	430	18	24	8.2	12	150	220
4	40	63	220	330	24	33	11	16	100	150
5	32	57	180	270	30	43	13	20	82	120
6	25	50	150	220	36	56	16	24	68	100
7	20	45	130	180	47	68	18	27	56	82
8	16	40	120	160	51	75	22	33	47	68
9	12.6	35	100	150	62	91	24	36	39	56
10	10	32	100	130	75	100	24	36	36	51
20	01	10	62	82	240	360	43	62	10	15

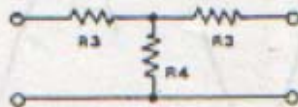

It is important that the wattage ratings of the resistors be chosen with care. Any appreciable power dissipation will cause the resistors to overheat. A 3 dB pad would dissipate 1/2 the power applied. If 20 watts were being reduced to a 10 watt output, the pad resistors would have to dissipate the other 10 watts.

Occasionally it becomes necessary to match a 50 ohm cable to a 72 ohm cable. The following pad may be used for this purpose. All pads have inherent losses however. This one has a loss of about 5 dB in either direction. This means about 32% of the power is actually transferred. The wattage rating of the pad must be able to dissipate the lost power safely.

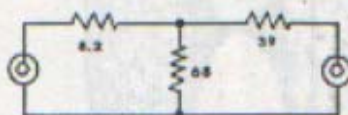

APPENDIX G

Typical RF Waveforms

The best way to check your RF output signal is with an oscilloscope. You can inspect the waveshape of the carrier for distortion which will give you some idea if you're producing unwanted harmonics. A check of the modulation envelope will determine if you are over-modulating. Over-modulation is heard by the listener as bad audio distortion. In addition, over modulation and carrier distortion probably will cause harmful interference to other stations on the band.

(A) shows 1 cycle of the carrier wave without modulation.

The time from the beginning of the cycle to the end is $1/1,000,000$ (1 microsecond) of a second if the carrier is 1,000 kilohertz.

This is good looking sine-wave.

(B) shows "cross-over" distortion. Bias on amplifier should be adjusted.

(C) shows "flat-topping", amplifier is overdriven, reduce power output.

(D) shows the modulation envelope at 100% modulation. Good shape.

(E) shows overmodulation (audio distortion), reduce modulation.

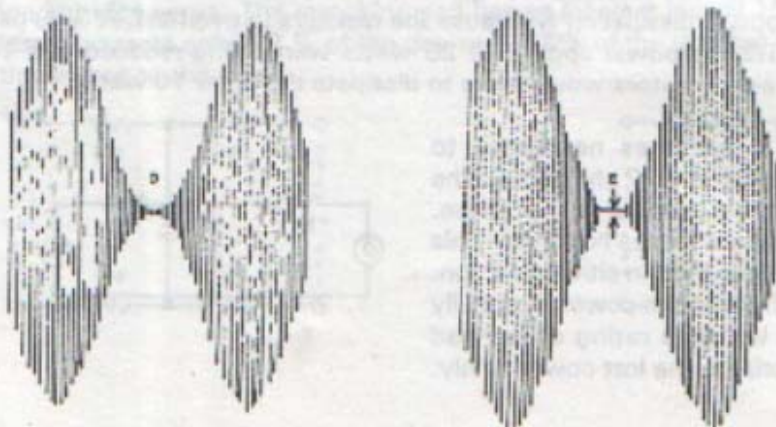

Hi-Quality CFR-47 Pt 15 Antenna System

Copyright 2002:
 Rev. Robert P. Chrysaifis

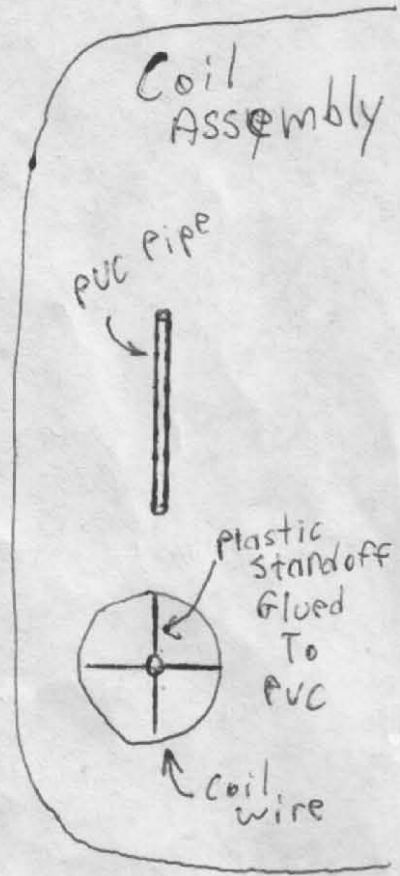
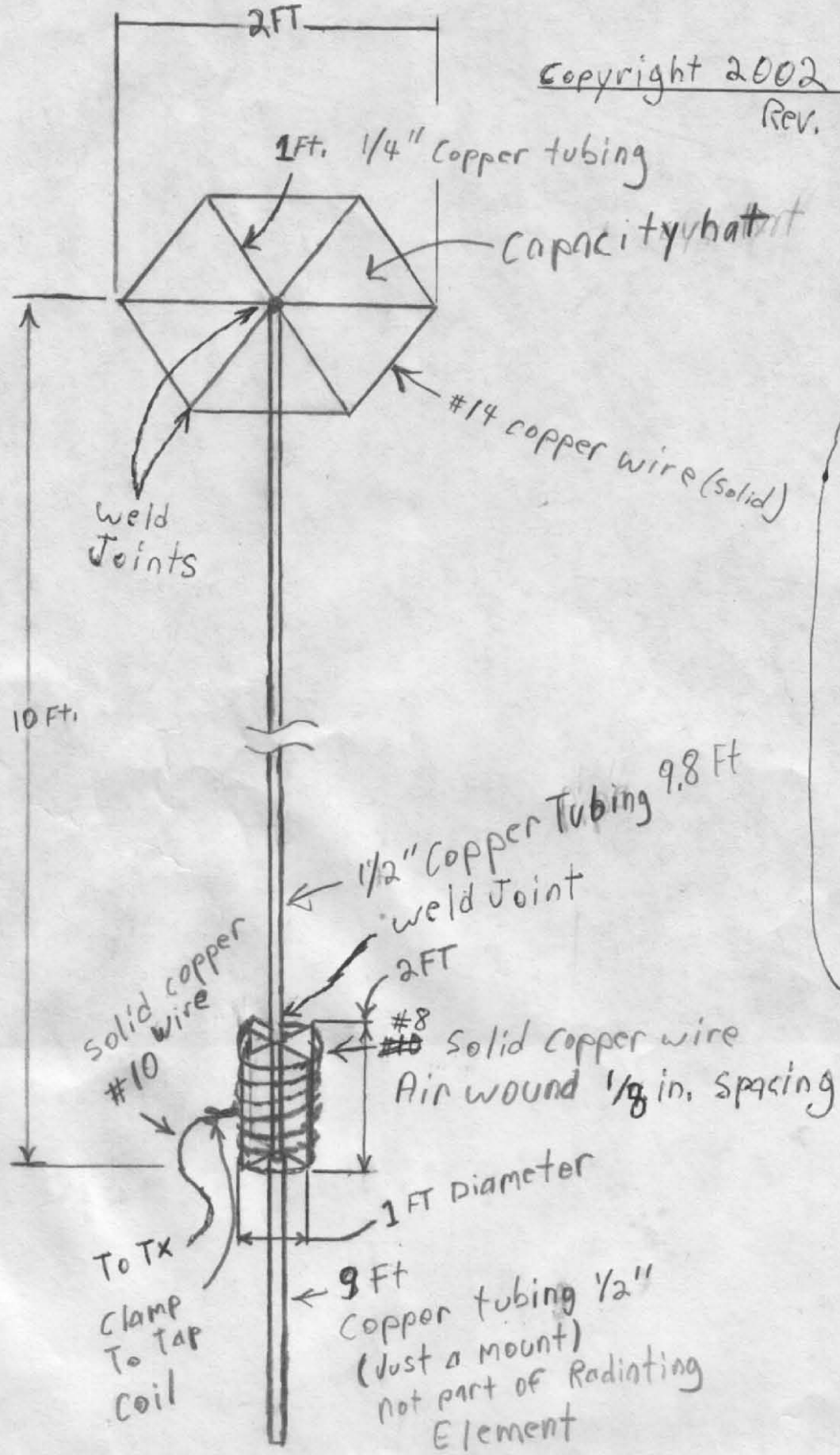

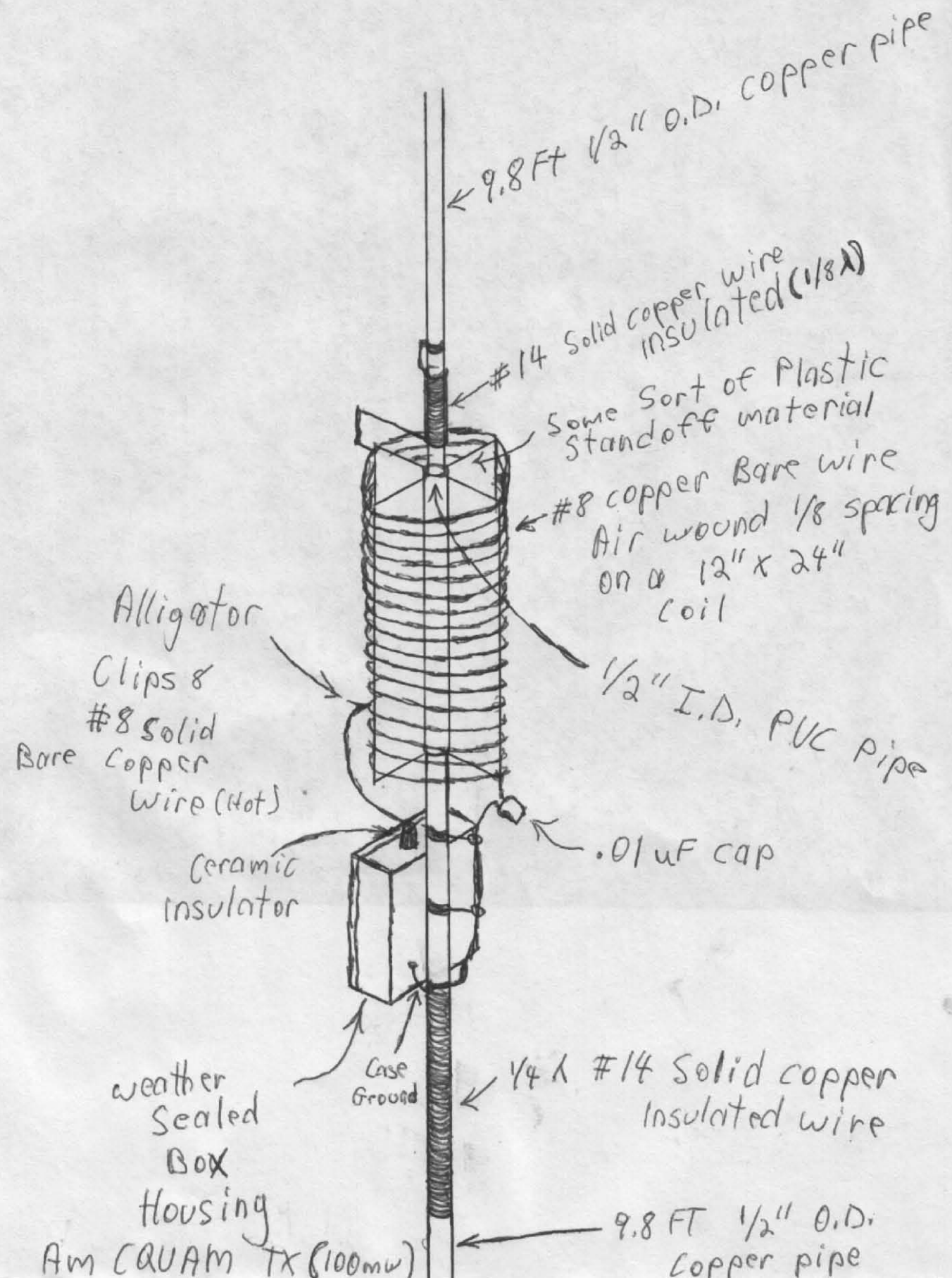

These Antenna Designs Are Copyright
2002 By Rev. Robert A. Chrysaflis

Any Addition or Corrections/changes Are
To Be made on a seperate paper and
Included with original plans. Sign your name
on your sheet noting those Additions or correction
~~were~~ made by you. Also Send a copy of
Additions or Corrections/changes to kc8gpd@
hotmail.com in Bmp, Pdf, or Doc Format.

Thanks,

Rev. Robert A. Chrysaflis